

Performance Specification

Model	Marking	V _{max}	I _{max}	I _{hold}	I _{trip}	P _d	Maximum Time To Trip		Resistance	
		(V dc)	(A)	@25°C (A)	@25°C (A)	Typ. (W)	Current (A)	Time (Sec)	R _{i min} (Ω)	R _{1max} (Ω)
SMD0603R001SF	X	60	20	0.01	0.03	0.5	0.2	1.00	15.000	100.000
SMD0603R002SF	Y	60	20	0.02	0.06	0.5	0.2	1.00	12.000	70.000
SMD0603R003SF	Z	30	20	0.03	0.09	0.5	0.2	1.00	6.000	50.000
SMD0603R004SF	-	24.0	20	0.04	0.12	0.5	0.20	1.00	4.000	40.000
SMD0603R005SF	-	15.0	20	0.05	0.15	0.5	0.25	1.00	3.800	30.000
SMD0603R010SF	1	15.0	40	0.10	0.30	0.5	0.5	1.00	0.900	6.000
SMD0603R020SF	2	9.0	40	0.20	0.50	0.5	1.0	0.60	0.550	3.500
SMD0603R020SF16v	2	16.0	40	0.20	0.50	0.5	1.0	0.60	0.550	3.500
SMD0603R025SF	2	9.0	40	0.25	0.55	0.5	8.0	0.08	0.500	3.000
SMD0603R025SF16v	2	16.0	40	0.25	0.55	0.5	8.0	0.08	0.500	3.000
SMD0603R035SF	3	6.0	40	0.35	0.75	0.5	8.0	0.10	0.200	1.000
SMD0603R040SF	5	6.0	40	0.40	0.80	0.5	8.0	0.10	0.150	0.800
SMD0603R050SF	5	6.0	40	0.50	1.00	0.5	8.0	0.10	0.100	0.680
SMD0603R050SF12v	5	12.0	40	0.50	1.00	0.5	8.0	0.10	0.100	0.680
SMD0603R060SF	7	6.0	40	0.60	1.20	0.5	8.0	0.10	0.080	0.600
SMD0603R065SF	7	6.0	40	0.65	1.30	0.5	8.0	0.10	0.070	0.550
SMD0603R075SF	7	6.0	40	0.75	1.40	0.5	8.0	0.10	0.060	0.450

V_{max} = Maximum operating voltage device can withstand without damage at rated current (I_{max}).

I_{max} = Maximum fault current device can withstand without damage at rated voltage (V_{max}).

I_{hold} = Hold Current. Maximum current device will not trip in 25°C still air.

I_{trip} = Trip Current. Minimum current at which the device will always trip in 25°C still air.

P_d = Power dissipation when device is in the tripped state in 25°C still air environment at rated voltage.

R_{i min/max} = Minimum/Maximum device resistance prior to tripping at 25°C.



R_{1max} = Maximum device resistance is measured one hour post reflow.

CAUTION : Operation beyond the specified ratings may result in damage and possible arcing and flame.

Environmental Specifications

Test	Conditions	Resistance change
Passive aging	+85°C, 1000 hrs.	±5% typical
Humidity aging	+85°C, 85% R.H. , 168 hours	±5% typical
Thermal shock	+85°C to -40°C, 20 times	±33% typical
Resistance to solvent	MIL-STD-202, Method 215	No change
Vibration	MIL-STD-202, Method 201	No change
Ambient operating conditions : - 40 °C to +85 °C		
Maximum surface temperature of the device in the tripped state is 125 °C		

Agency Approval and Environmental Compliance

Agency	File Number	Regulation	Standard
UL	pending		2002/95/EC
TUV	pending		EN14582

Thermal Derating Chart

Recommended Hold Current(A) at Ambient Temperature(°C)

Model	Ambient Operation Temperature								
	-40°C	-20°C	0°C	25°C	40°C	50°C	60°C	70°C	85°C
SMD0603R001SF	0.016	0.014	0.012	0.010	0.008	0.007	0.006	0.005	0.0035
SMD0603R002SF	0.031	0.027	0.024	0.020	0.016	0.014	0.012	0.011	0.007
SMD0603R003SF	0.047	0.041	0.036	0.030	0.024	0.021	0.018	0.016	0.0108
SMD0603R004SF	0.052	0.048	0.044	0.040	0.032	0.028	0.024	0.020	0.012
SMD0603R005SF	0.065	0.060	0.055	0.050	0.040	0.035	0.031	0.025	0.015
SMD0603R010SF	0.13	0.12	0.11	0.10	0.08	0.07	0.06	0.05	0.03
SMD0603R020SF	0.27	0.25	0.23	0.20	0.17	0.14	0.12	0.10	0.07
SMD0603R025SF	0.32	0.29	0.27	0.25	0.21	0.18	0.16	0.14	0.10
SMD0603R035SF	0.47	0.41	0.38	0.35	0.29	0.26	0.24	0.20	0.14
SMD0603R040SF	0.54	0.47	0.43	0.40	0.33	0.29	0.27	0.22	0.16
SMD0603R050SF	0.67	0.59	0.54	0.50	0.41	0.37	0.34	0.29	0.20
SMD0603R060SF	0.81	0.70	0.651	0.60	0.49	0.44	0.41	0.34	0.24
SMD0603R065SF	0.87	0.76	0.71	0.65	0.54	0.48	0.44	0.37	0.26
SMD0603R075SF	0.98	0.85	0.81	0.75	0.60	0.54	0.44	0.40	0.31

Thermal Derating Curve

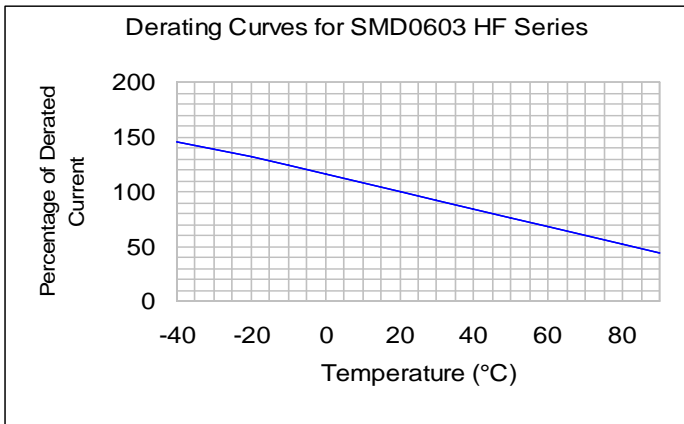

Average Time-Current Curve

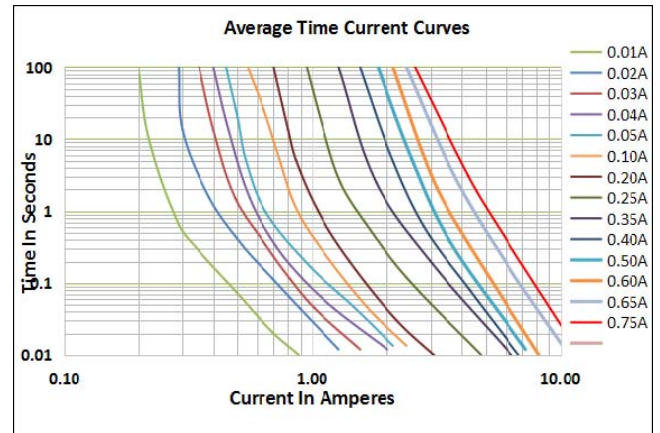

Soldering Parameters

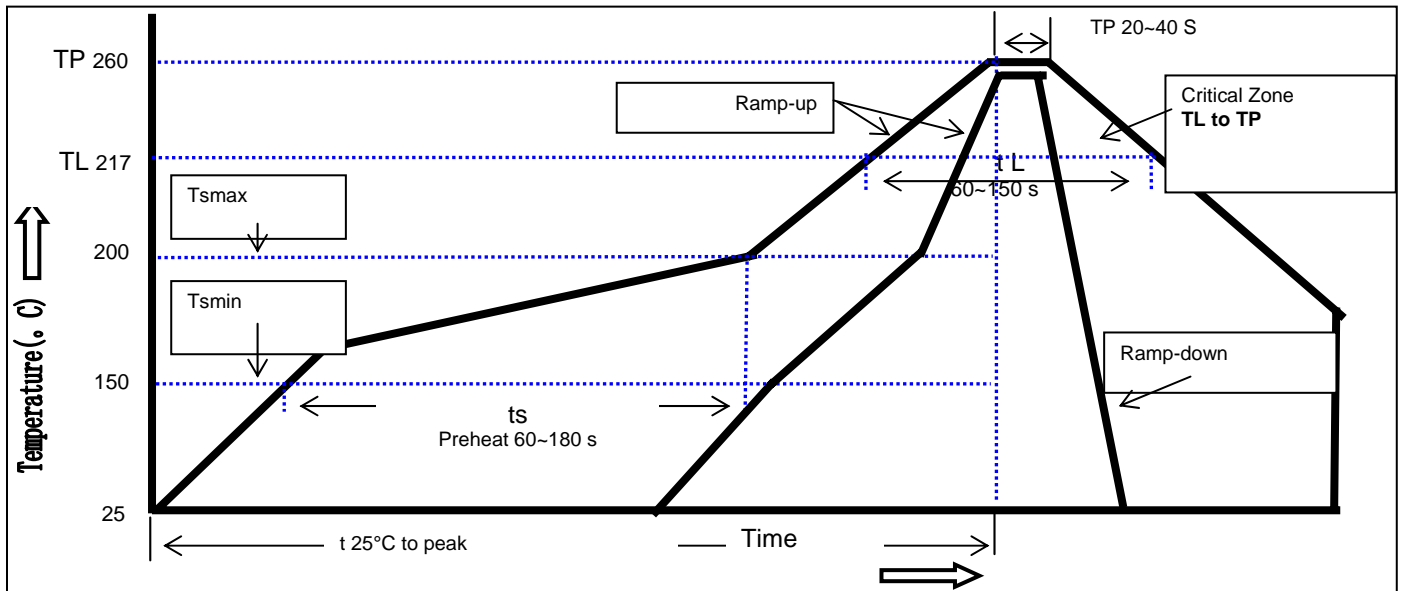

Profile Feature	Pb-Free Assembly
Average Ramp-Up Rate(Ts max to T p)	3°C/second max.
Preheat	
-Temperature Min(Ts min)	150°C
-Temperature Max(Ts max)	200°C
-Time(Ts min to Ts max)	60~180 seconds
Time maintained above:	
-Temperature(TL)	217°C
-Time(tL)	60~150 seconds
Peak Temperature(Tp)	260°C
Ramp-Down Rate	6°C/second max.
Time 25°C to Peak Temperature	8 minutes max
Storage Condition	0°C~35°C,30%-60%RH

Recommended reflow methods: IR, vapor phase oven, hot air oven, N2 environment for lead-free

Recommended maximum paste thickness is 0.25mm

Devices can be cleaned using standard industry methods and solvents.

Note 1:All temperature refer to topside of the package, measured on the package body surface.

Note 2: If reflow temperatures exceed the recommended profile, devices may not meet the performance requirements.

Physical Dimensions(mm.)

Model	A		B		C		D	E
	Min.	Max.	Min.	Max.	Min.	Max.	Min.	Min.
SMD0603R001SF	1.45	1.85	0.65	1.05	0.40	1.00	0.15	0.10
SMD0603R002SF	1.45	1.85	0.65	1.05	0.40	1.00	0.15	0.10
SMD0603R003SF	1.45	1.85	0.65	1.05	0.40	1.00	0.15	0.10
SMD0603R004SF	1.45	1.85	0.65	1.05	0.40	1.00	0.15	0.10
SMD0603R005SF	1.45	1.85	0.65	1.05	0.40	1.00	0.15	0.10
SMD0603R010SF	1.45	1.85	0.65	1.05	0.40	1.00	0.15	0.10
SMD0603R020SF	1.45	1.85	0.65	1.05	0.40	1.00	0.15	0.10
SMD0603R020SF16v	1.45	1.85	0.65	1.05	0.40	1.00	0.15	0.10
SMD0603R025SF	1.45	1.85	0.65	1.05	0.40	1.00	0.15	0.10
SMD0603R025SF16v	1.45	1.85	0.65	1.05	0.40	1.00	0.15	0.10
SMD0603R035SF	1.45	1.85	0.65	1.05	0.35	0.90	0.15	0.10
SMD0603R040SF	1.45	1.85	0.65	1.05	0.40	0.90	0.15	0.10
SMD0603R050SF	1.45	1.85	0.65	1.05	0.55	1.15	0.15	0.10
SMD0603R050SF12v	1.45	1.85	0.65	1.05	0.55	1.15	0.15	0.10
SMD0603R060SF	1.45	1.85	0.65	1.05	0.55	1.15	0.15	0.10
SMD0603R065SF	1.45	1.85	0.65	1.05	0.55	1.15	0.15	0.10
SMD0603R075SF	1.45	1.85	0.65	1.05	0.55	1.15	0.15	0.10

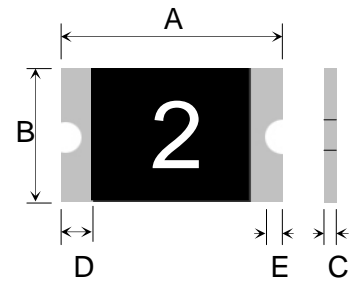

Termination Pad Characteristics
 Terminal pad materials: Tin-plated Nickel-Copper
 Terminal pad solder ability: Meets EIA specification RS186-9E and ANSI/J-STD-002 Category 3.

Recommended Pad Layout (mm.)

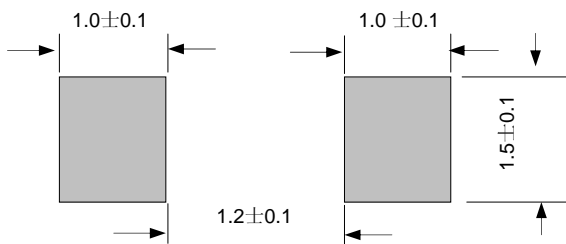

Packaging Quantity

Part Number	Quantity
SMD0603 HF Series	4,000 pcs/reel

Tape & reel packaging per EIA481-1

Tape And Reel Specifications (mm)

Governing Specifications	EIA 481-1
W	8.0 ± 0.2
P ₀	4.0 ± 0.10
P ₁	4.0 ± 0.10
P ₂	2.0 ± 0.05
A ₀	1.05 ± 0.10
B ₀	1.85 ± 0.10
D ₀	1.55 + 0.05
F	3.5 ± 0.05
E ₁	1.75 ± 0.10
E ₂ min.	6.25
T	0.75
T ₁ max.	0.1
K ₀	0.75/0.95 ± 0.1
Leader min.	390
Trailer min.	160
Reel Dimensions	
A max.	178
N min.	60
W ₁	9.0 ± 0.5
W ₂	12.0 ± 0.05
W	8.0 ± 0.2
Storage And Handling	
· Storage conditions: 35°C max, 30%-60% R.H.	
· Devices may not meet specified performance if storage conditions are exceeded.	

EIA Tape Component Dimensions P₀

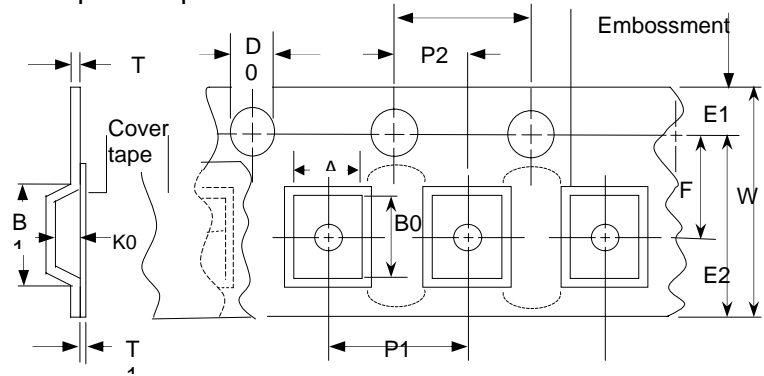

EIA Reel Dimensions

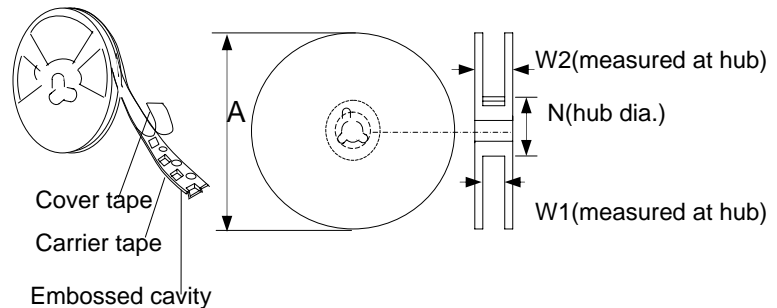

Part Number System

SMD 0603 R □□□ S F □□V

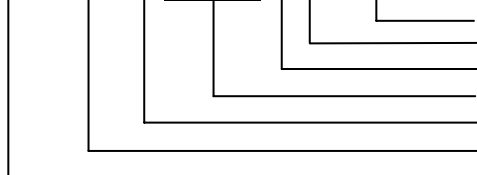

- special voltage Rating(Optional)
- Lead-Free
- Tin-plated Nickel-Copper
- Holding Current Rating
- Logo
- Device Dimensions: Length/width(Unit:1/100 inch) Size 2012 mm / 0805 inch
- Surface Mount Device