

Type GTH

Time-Lag Ceramic Tube Fuses Series



Description

GTH Time-lag type, 125V/250V/350V/500V rated designed In accordance to IEC 60127, GB9364.

Features

- Lead-free
- Internationally approved
- Reduced PCB space requirements
- Direct Solderability or plug-in versions
- Low internal resistance
- Shock safe casing
- Vibration resistant
- Halogen free

Applications

- Power supplies
- Battery Chargers
- Consumer Electronics
- Industrial Controllers
- Adapter

Agency Approvals.

Safety Agency	Agency File Number	Ampere Range Volt@I.R.Ability
	40005299	1A-6.3A 250VAC@1500A 1-6.3A 125VAC@10kA
	2010010207439042	1A-6.3A 250VAC@1500A 1-6.3A 125VAC@10kA
	17012183837	16A 250VAC@1500A 16A 125VAC@10kA
	E485357	100mA-25A 125VAC@10kA 100mA-10A 250VAC@1500A 12.5A-25A 250VAC@300A 100mA-25A 250Vdc@300A 100mA-25A 350VAC@300A 100mA-25A 350Vdc@300A 100mA-25A 500VAC@300A 100mA-25A 500Vdc@300A

Electrical Characteristics for Series

% of Ampere Rating	Opening Time
110%	1 Hour ,Min
210%	30min,Max
275%	1s Min,80s Max
400%	150ms Min,5s Max
1000%	20ms Min,150ms Max

Electrical Characteristic Specifications by Item

Catalog Number	Rated Current	Voltage Rating	Breaking Capacity	Melting Integral 10In min(A2S)	Agency Approvals				
					VDE	CCC	cURus	CQC	
GTH1100	1A	125VAC 250VAC 250VDC 350VAC 350VDC 500VAC 500VDC	125Vac@10kA 250Vac@1500A 250Vdc@300A 350Vac@300A 350Vdc@300A 500Vac@300A 500Vdc@300A	3.000	●	●	●		
GTH1125	1.25A			4.844	●	●	●		
GTH1160	1.6A			8.704	●	●	●		
GTH1200	2A			15.600	●	●	●		
GTH1250	2.5A			23.125	●	●	●		
GTH1315	3.15A			32.744	●	●	●		
GTH1400	4A			54.400	●	●	●		
GTH1500	5A			85.000	●	●	●		
GTH1630	6.3A			138.915	●	●	●		
GTH1800	8A			236.800			●		
GTH2100	10A			360.000			●		
GTH1125	12.5A			578.125	125Vac@10kA 250VAC/DC@300A 350VAC/DC@300A 500VAC/DC@300A			●	
GTH2150	15A			1035.00				●	
GTH2160	16A			1177.60				●	●
GTH2200	20A			1600.00				●	
GTH2250	25A			2500.00				●	

Type GTH

Time-Lag Ceramic Tube Fuses Series



Temperature Re-rating Curve

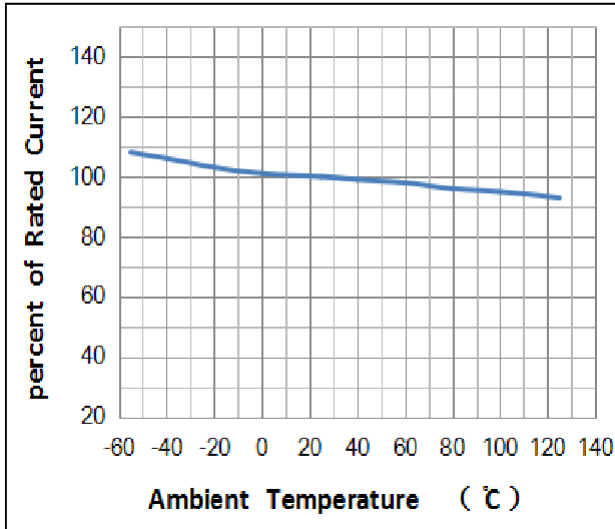

Average Time Current Curves

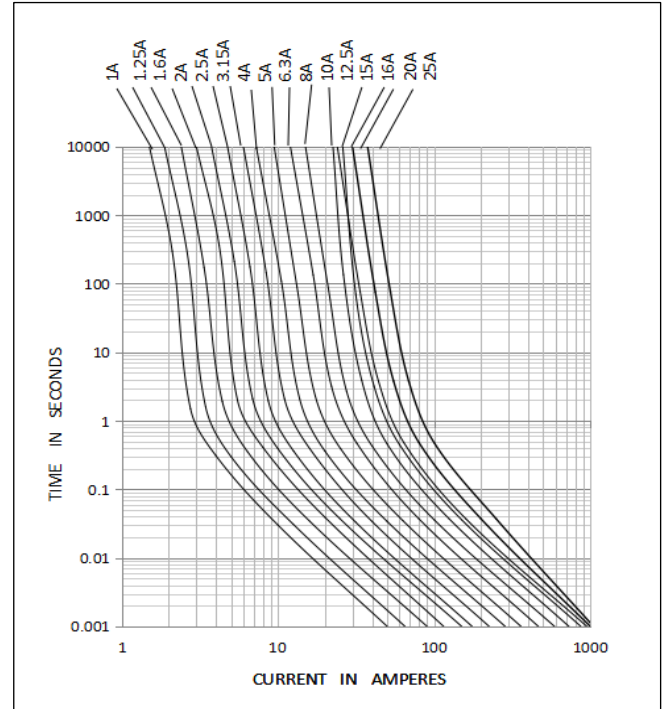

Soldering Parameters-Wave Soldering

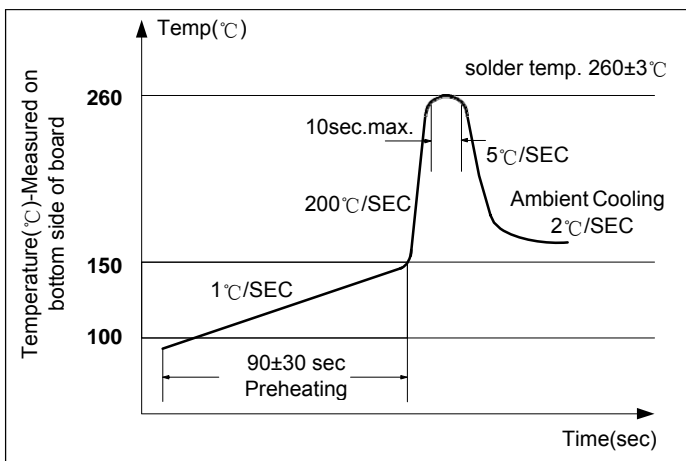

Recommended Process Parameters:

Lead-Free Wave Soldering Profile	
Wave Soldering Parameter	
Average ramp-up rate	200 °C/second
Heating rate during preheat	Typical 1-2 °C/second Max 4 °C/second
Final preheat temperature	Within 125 °C of soldering temperature
Peak temperature	260 °C
Time within +0 °C/-5 °C of actual peak temperature	10 seconds
Ramp-down rate	5 °C/second max

Type GTH

Time-Lag Ceramic Tube Fuses Series



Product Characteristics

Materials	Ceramic Body Nickel Plated Brass Caps Lead Wire :Diameter 1.0mm Sheath : Diameter 5.0mm
Lead Pull Strength	10 N(IEC 60068-2-21)
Soldering Parameters	260 °C, ≤10 sec.(wave) 350 °C, ≤3 sec.(soldering iron)
Soldering Heat Resistance	260 °C, 10 sec.(IEC 60068-2-20) 350 °C, ≤3 sec.(soldering iron)

Operating Temperature	-55 °C to +125 °C (consider de-rating)
Climatic Category	-40 °C to +85 °C/21 days (EN 60068-1, -2-1, -2-2, -2-78)
Stock Condition	+10 °C to +60 °C Relative humidity ≤75% yearly Average, without dew, maximum Value for 30 days -95%
Vibration Resistance	24 cycles at 15 min. each (EN 60068-2-6) 10-60 Hz at 0.75 mm amplitude 60-2000 Hz at 10 g acceleration

Mechanical Dimensions(Unit:mm)

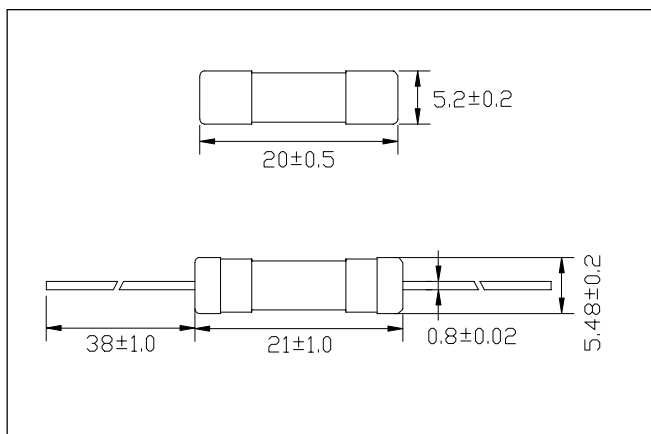

*Note:20A~25A Lead Φ1.2mm

Ordering Information

FUSE TYPE	GTH	2100	5	01
GTH				
AMPERE RATING				
10A(10 ² x100mA)				
VOLTAGE RATING				
1:125V 2:250V 3:350V 5:500V				
COMPLEMENT				
00:Standard 01:Axial Lead				

Packaging

Packaging Option	Packaging Specification	Quantity
Standard(00)	N / A	500
Axial Lead(01)	N / A	100