

Enhancement Mode N-Channel Power MOSFET

Features

- ◆ Low $R_{DS(on)}$ & FOM
- ◆ Extremely low switching loss
- ◆ Excellent stability and uniformity
- ◆ Easy to drive

Applications

- ◆ Lighting
- ◆ Hard switching PWM
- ◆ Server power supply
- ◆ Charger

■ General Description

OSG55R580xF use advanced GreenMOSTM technology to provide low $R_{DS(ON)}$, low gate charge, fast switching and excellent avalanche characteristics. This device is suitable for active power factor correction and switching mode power supply applications.

◆ $V_{DS, min@Tjmax}$	600 V
◆ $I_{D, pulse}$	24 A
◆ $R_{DS(ON), max @ V_{GS}=10 V}$	580 mΩ
◆ Q_g	8.7 nC

■ Schematic and Package Information

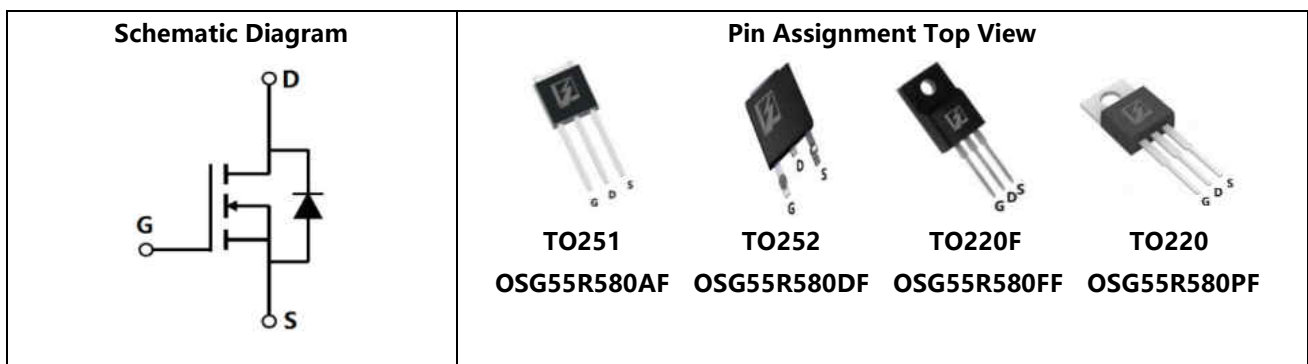

■ Absolute Maximum Ratings at $T_j=25^{\circ}\text{C}$ unless otherwise noted

Parameter	Symbol	Value	Unit
Drain source voltage	V_{DS}	550	V
Gate source voltage	V_{GS}	± 30	V
Continuous drain current ¹⁾ , $T_C=25^{\circ}\text{C}$	I_D	8	A
Continuous drain current ¹⁾ , $T_C=100^{\circ}\text{C}$		5	
Pulsed drain current ²⁾ , $T_C=25^{\circ}\text{C}$	$I_{D, pulse}$	24	A
Power dissipation ³⁾ for TO251, TO252, TO220, $T_C=25^{\circ}\text{C}$	P_D	37	W
Power dissipation ³⁾ for TO220F, $T_C=25^{\circ}\text{C}$		26	
Single pulsed avalanche energy ⁵⁾	E_{AS}	130	mJ
MOSFET dv/dt ruggedness, $V_{DS}=0\text{...}440\text{ V}$	dv/dt	50	V/ns
Reverse diode dv/dt, $V_{DS}=0\text{...}440\text{ V}$, $I_{SD}\leq I_D$	dv/dt	15	V/ns
Operation and storage temperature	T_{stg}, T_j	-55 to 150	$^{\circ}\text{C}$



■ Thermal Characteristics

Parameter	Symbol	Value		Unit
		TO251/TO252/TO220	TO220F	
Thermal resistance, junction-case	$R_{\theta JC}$	3.4	4.8	°C/W
Thermal resistance, junction-ambient ⁴⁾	$R_{\theta JA}$	62	62.5	°C/W

■ Electrical Characteristics at $T_j=25\text{ }^\circ\text{C}$ unless otherwise specified

Parameter	Symbol	Min.	Typ.	Max.	Unit	Test condition
Drain-source breakdown voltage	BV_{DSS}	550			V	$V_{GS}=0\text{ V}$, $I_D=250\text{ }\mu\text{A}$
		600	670			$V_{GS}=0\text{ V}$, $I_D=250\text{ }\mu\text{A}$, $T_j=150\text{ }^\circ\text{C}$
Gate threshold voltage	$V_{GS(th)}$	2.0		4.0	V	$V_{DS}=V_{GS}$, $I_D=250\text{ }\mu\text{A}$
Drain-source on-state resistance	$R_{DS(on)}$		0.5	0.58	Ω	$V_{GS}=10\text{ V}$, $I_D=4\text{ A}$
			1.17			$V_{GS}=10\text{ V}$, $I_D=4\text{ A}$, $T_j=150\text{ }^\circ\text{C}$
Gate-source leakage current	I_{GSS}			100	nA	$V_{GS}=30\text{ V}$
				-100		$V_{GS}=-30\text{ V}$
Drain-source leakage current	I_{DSS}			1	μA	$V_{DS}=550\text{ V}$, $V_{GS}=0\text{ V}$

■ Dynamic Characteristics

Parameter	Symbol	Min.	Typ.	Max.	Unit	Test condition
Input capacitance	C_{iss}		357.6		pF	$V_{GS}=0\text{ V}$, $V_{DS}=50\text{ V}$, $f=1\text{ MHz}$
Output capacitance	C_{oss}		46.6		pF	
Reverse transfer capacitance	C_{rss}		1.73		pF	
Turn-on delay time	$t_{d(on)}$		17.3		ns	$V_{GS}=10\text{ V}$, $V_{DS}=400\text{ V}$, $R_G=25\text{ }\Omega$, $I_D=3.5\text{ A}$
Rise time	t_r		8.4		ns	
Turn-off delay time	$t_{d(off)}$		28.9		ns	
Fall time	t_f		21.8		ns	



■ Gate Charge Characteristics

Parameter	Symbol	Min.	Typ.	Max.	Unit	Test condition
Total gate charge	Q_g		7.7		nC	$I_D=3.5\text{ A}$, $V_{DS}=400\text{ V}$, $V_{GS}=10\text{ V}$
Gate-source charge	Q_{gs}		1.8		nC	
Gate-drain charge	Q_{gd}		3.3		nC	
Gate plateau voltage	V_{plateau}		5.6		V	

■ Body Diode Characteristics

Parameter	Symbol	Min.	Typ.	Max.	Unit	Test condition
Diode forward current	I_S			8	A	$V_{GS} < V_{th}$
Pulsed source current	I_{SP}			24		
Diode forward voltage	V_{SD}			1.3	V	$I_S=8\text{ A}$, $V_{GS}=0\text{ V}$
Reverse recovery time	t_{rr}		165.9		ns	$I_S=3.5\text{ A}$, $di/dt=100\text{ A}/\mu\text{s}$
Reverse recovery charge	Q_{rr}		1.1		μC	
Peak reverse recovery current	I_{rrm}		12.6		A	

■ Note

- 1) Calculated continuous current based on maximum allowable junction temperature.
- 2) Repetitive rating; pulse width limited by max. junction temperature.
- 3) P_d is based on max. junction temperature, using junction-case thermal resistance.
- 4) The value of $R_{\theta JA}$ is measured with the device mounted on 1 in 2 FR-4 board with 2oz. Copper, in a still air environment with $T_a=25\text{ }^\circ\text{C}$.
- 5) $V_{DD}=50\text{ V}$, $R_G=25\text{ }\Omega$, $L=20\text{ mH}$, starting $T_j=25\text{ }^\circ\text{C}$.



■ Electrical Characteristics Diagrams

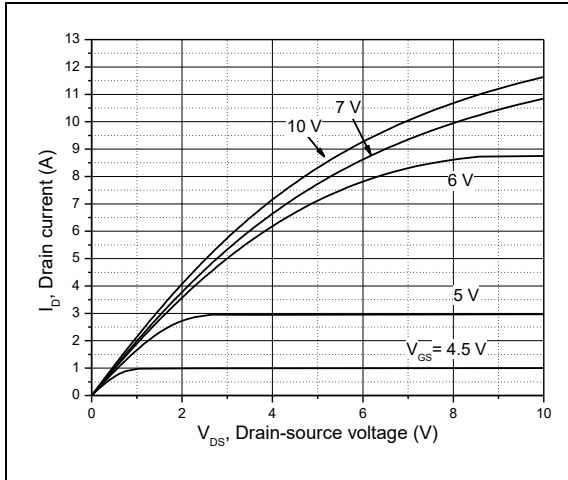

Figure 1, Typ. output characteristics

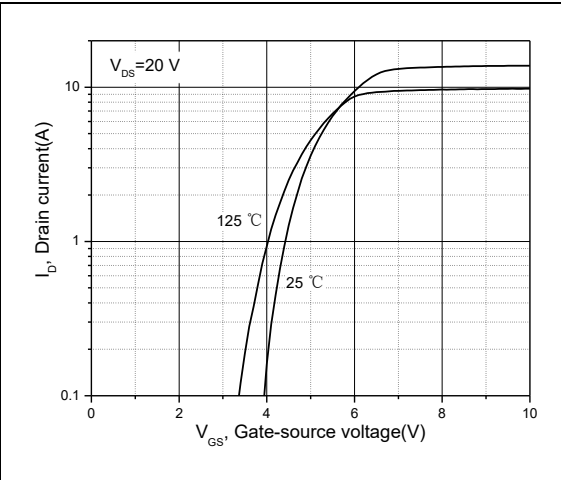

Figure 2, Typ. transfer characteristics

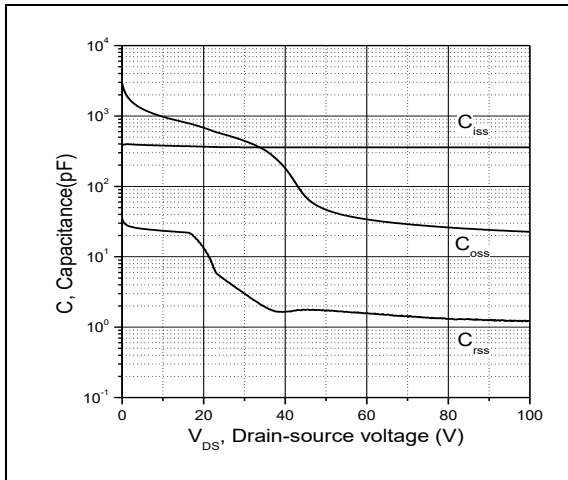

Figure 3, Typ. capacitances

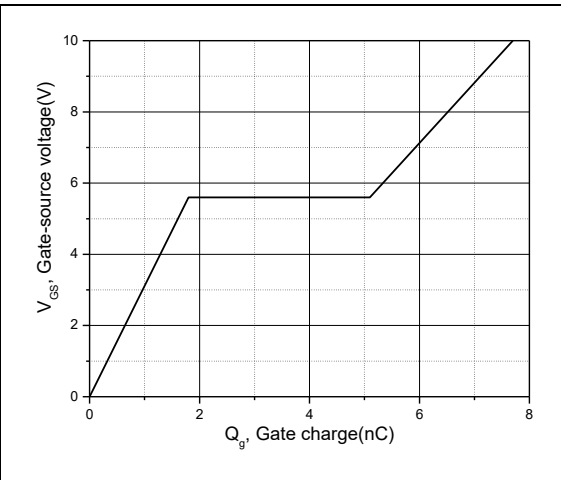

Figure 4, Typ. gate charge

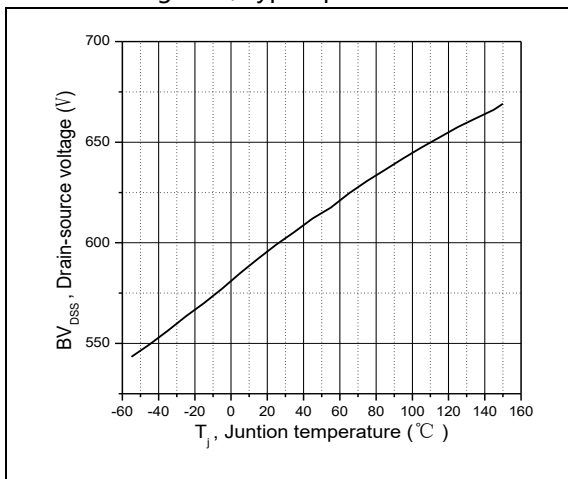

Figure 5, Drain-source breakdown voltage

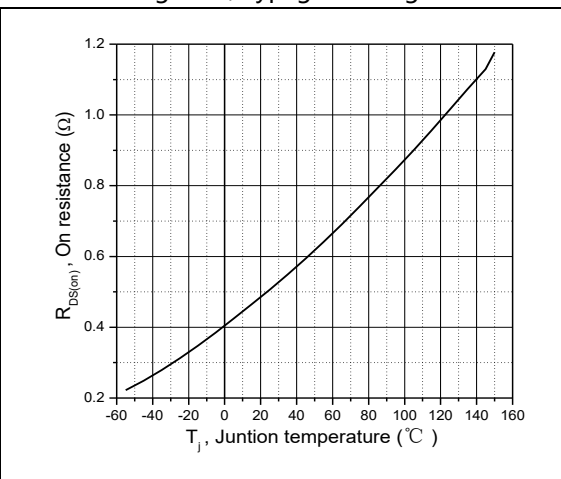

Figure 6, Drain-source on-state resistance

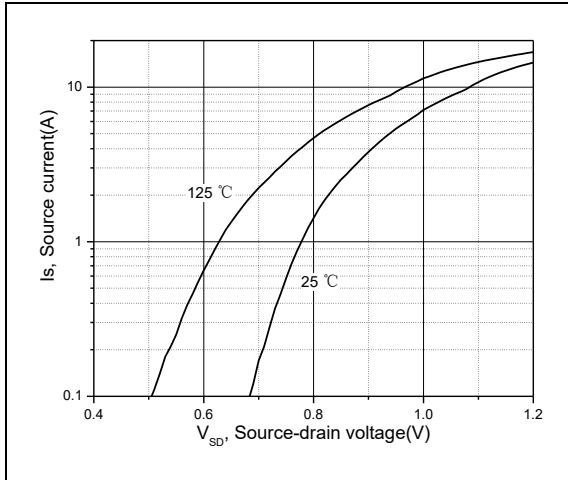

Figure 7, Forward characteristic of body diode

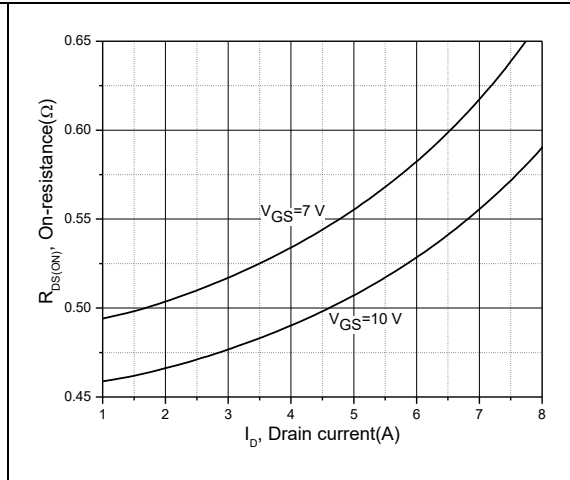

Figure 8, Drain-source on-state resistance

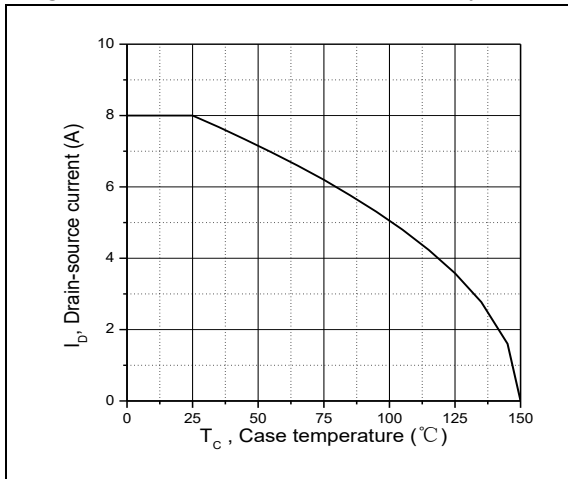

Figure 9, Drain current

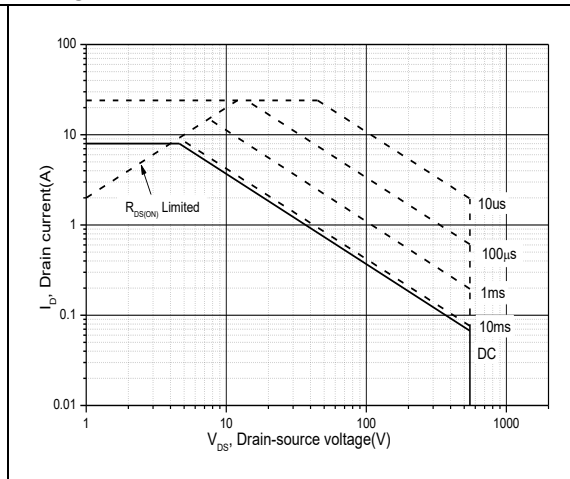

Figure 10, Safe operation area for TO251/TO252/TO220 $T_C=25\text{ }^\circ\text{C}$

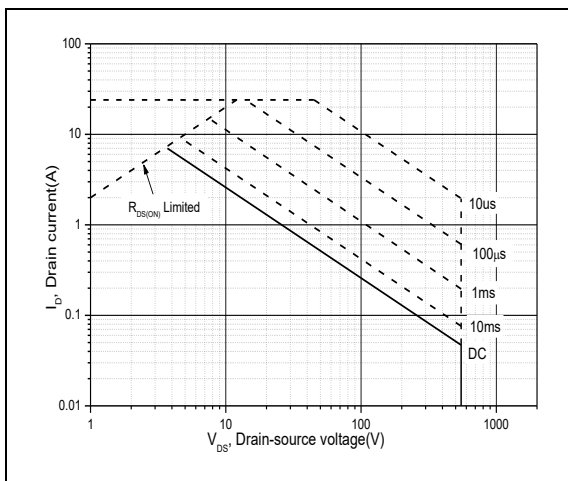
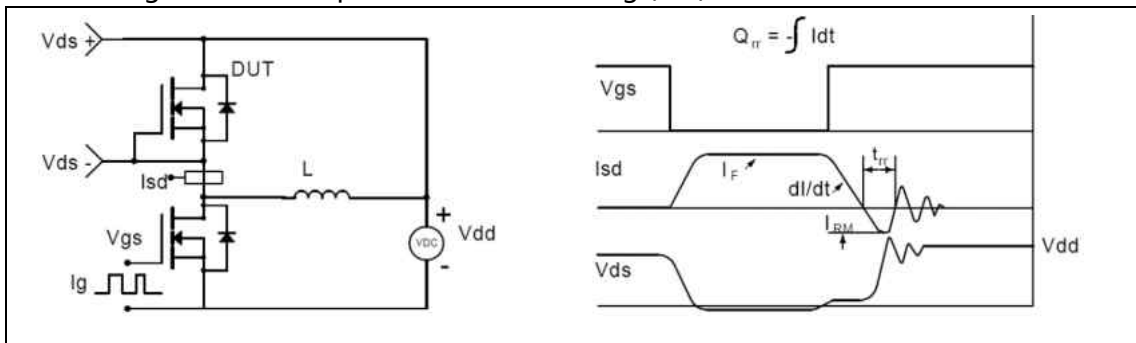
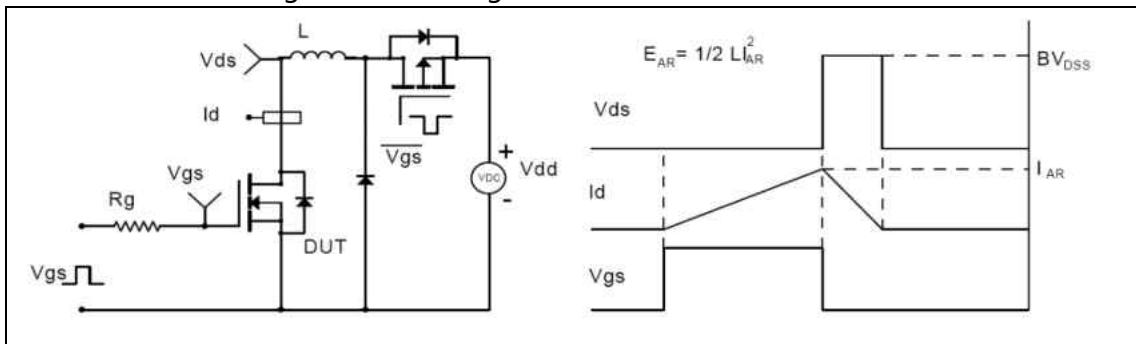
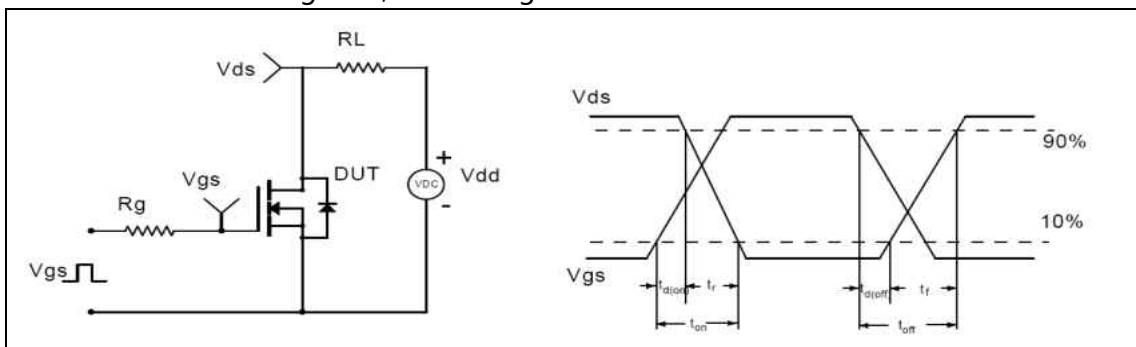
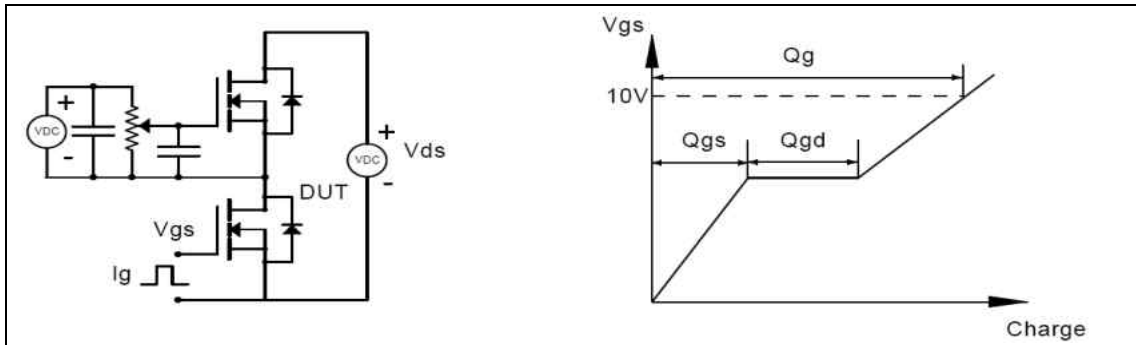

Figure 11, Safe operation area for TO220F $T_C=25\text{ }^\circ\text{C}$



■ Test circuits and waveforms





■ Package Information

Figure1, TO251 package outline dimension

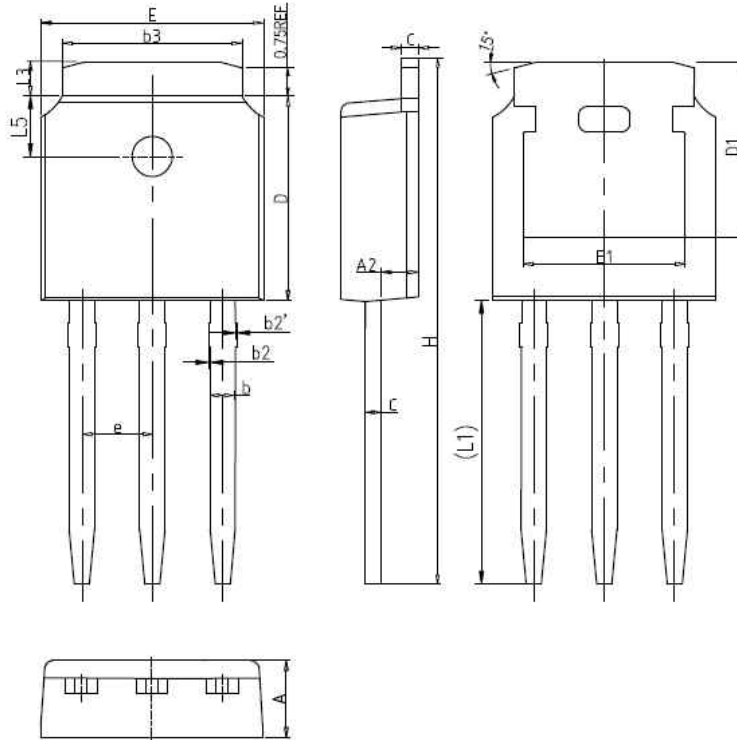

Symbol	Dimension In Millimeters			Dimension In Inches		
	Min	Nom	Max	Min	Nom	Max
A	2.200	2.300	2.400	0.087	0.091	0.094
A2	0.970	1.070	1.170	0.038	0.042	0.046
b	0.680	0.780	0.900	0.027	0.031	0.035
b2	0.000	0.040	0.100	0.000	0.002	0.004
b2'	0.000	0.040	0.100	0.000	0.002	0.004
b3	5.200	5.330	5.500	0.205	0.210	0.217
c	0.430	0.530	0.630	0.017	0.021	0.025
D	5.980	6.100	6.220	0.235	0.240	0.245
D1	5.300REF			0.209REF		
E	6.400	6.600	6.800	0.252	0.260	0.268
E1	4.630	-	-	0.182	-	-
e	2.286BSC			0.090BSC		
H	16.220	16.520	16.820	0.639	0.650	0.662
L1	9.150	9.400	9.650	0.360	0.370	0.380
L3	0.880	1.020	1.280	0.035	0.040	0.050
L5	1.650	1.800	1.950	0.065	0.071	0.077



■ Package Information

Figure2, TO252 package outline dimension

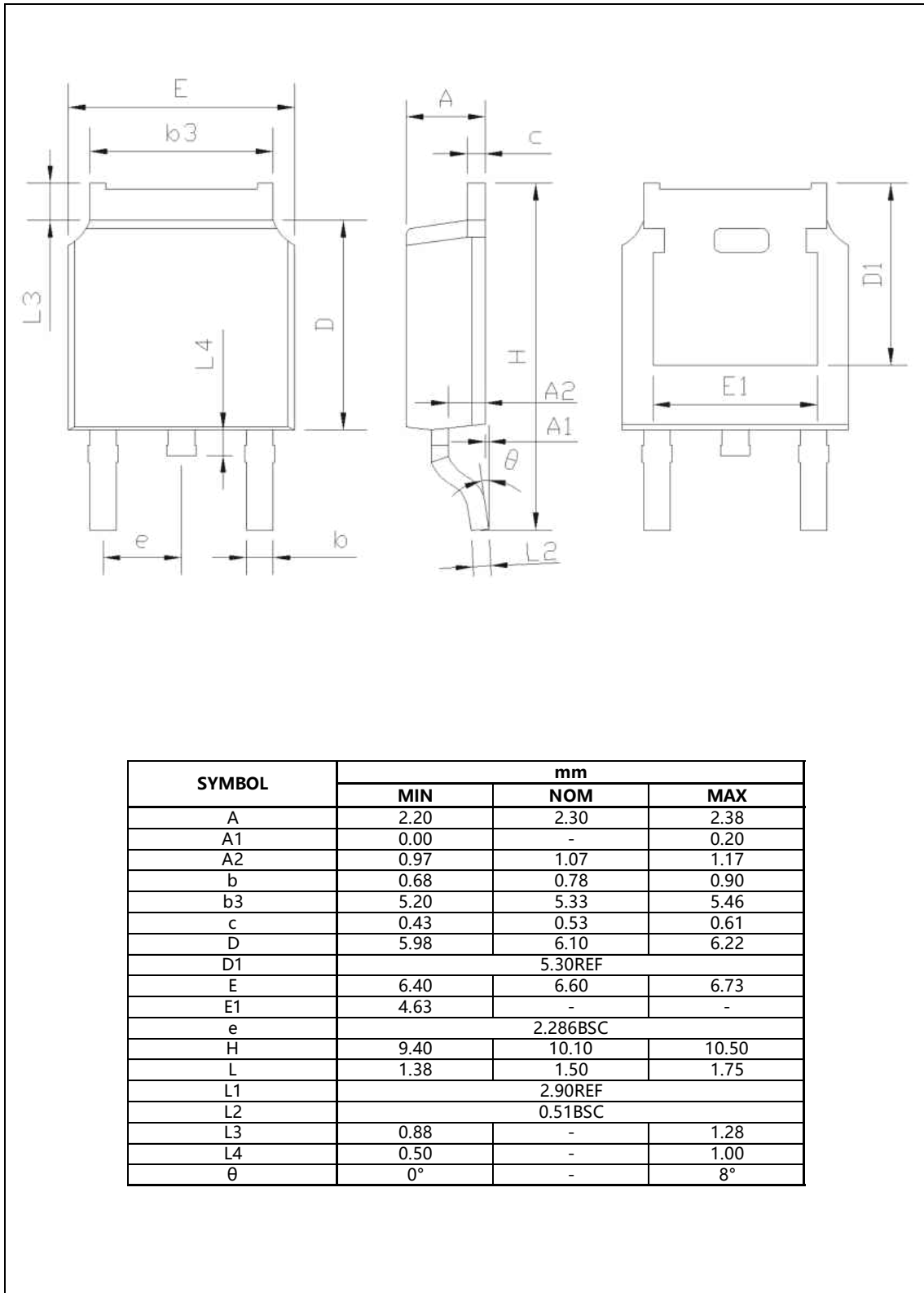



■ Package Information

Figure3, TO220F package outline dimension

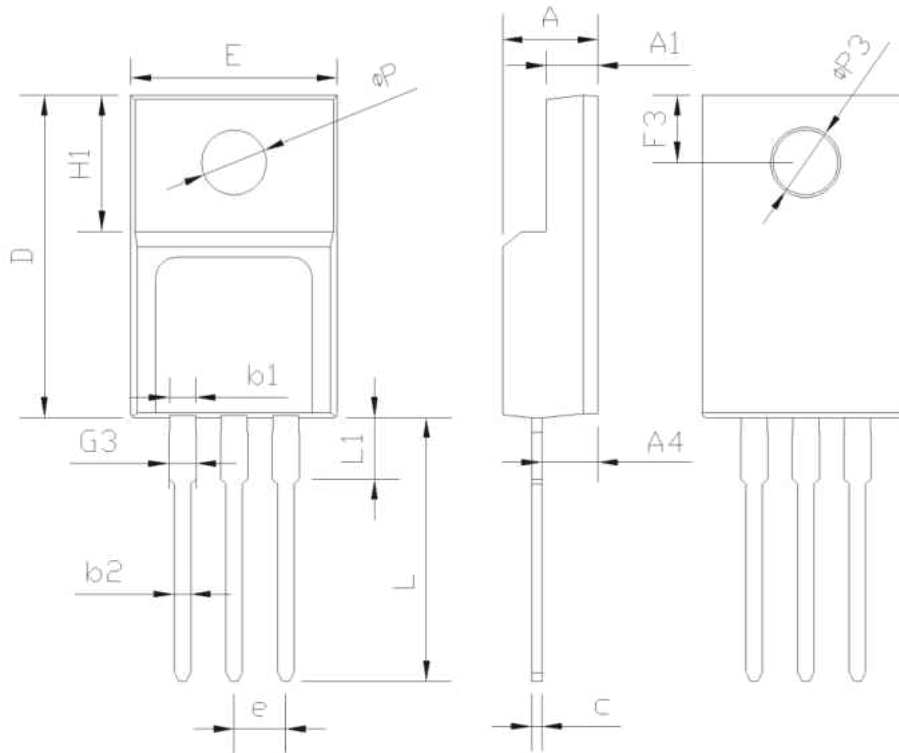

SYMBOL	mm		
	MIN	NOM	MAX
E	9.96	10.16	10.36
A	4.50	4.70	4.90
A1	2.34	2.54	2.74
A2	0.30	0.45	0.60
A4	2.56	2.76	2.96
c	0.40	0.50	0.65
c1	1.20	1.30	1.35
D	15.57	15.87	16.17
H1	6.70REF		
e	2.54BSC		
L	12.68	12.98	13.28
L1	2.88	3.03	3.18
ΦP	3.03	3.18	3.38
ΦP3	3.15	3.45	3.65
F3	3.15	3.30	3.45
G3	1.25	1.35	1.55
b1	1.18	1.28	1.43
b2	0.70	0.80	0.95



■ Package Information

Figure4, TO220 package outline dimension

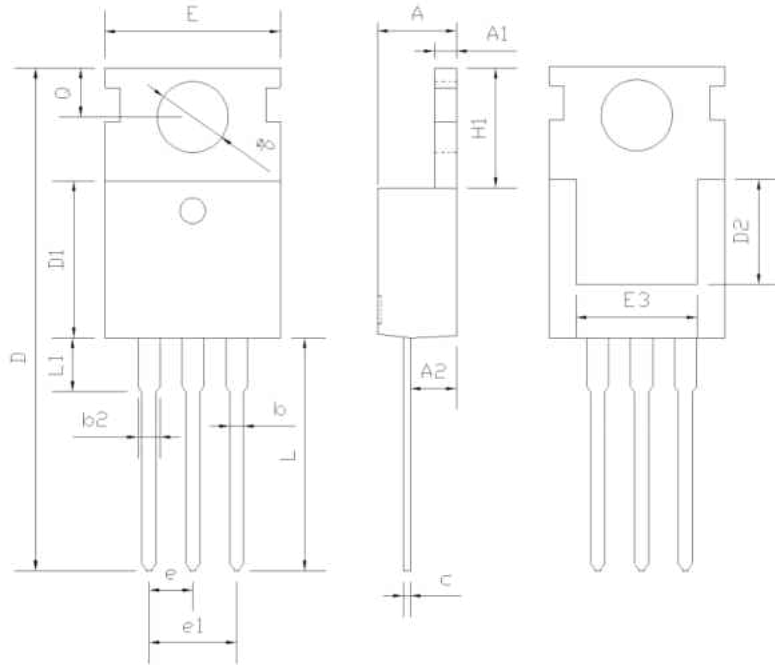

Symbol	Min	Nom	Max
A	4.37	4.57	4.77
A1	1.25	1.30	1.45
A2	2.20	2.40	2.60
b	0.70	0.80	0.95
b2	1.17	1.27	1.47
c	0.40	0.50	0.65
D	15.10	15.60	16.10
D1	8.80	9.10	9.40
D2	5.50	-	-
E	9.70	10.00	10.30
E3	7.00	-	-
e	2.54 BSC		
e1	5.08 BSC		
H1	6.25	6.50	6.85
L	12.75	13.50	13.80
L1	-	3.10	3.40
ΦP	3.40	3.60	3.80
Q	2.60	2.80	3.00



■ Ordering Information

Package	Units/Tube	Tubes/Inner Box	Units/Inner Box	Inner Box/Carton Box	Units/Carton Box
TO251	75	66	4950	6	29700
TO220F	50	20	1000	6	6000
TO220	50	20	1000	6	6000

Package	Units/Tape	Tapes/Inner Box	Units/Inner Box	Inner Box/Carton Box	Units/Carton Box
TO252	2500	2	5000	5	25000

■ Product Information

Product	Package	Pb Free	RoHS	Halogen Free
OSG55R580AF	TO251	yes	yes	yes
OSG55R580DF	TO252	yes	yes	yes
OSG55R580FF	TO220F	yes	yes	yes
OSG55R580PF	TO220	yes	yes	yes