

Enhancement Mode N-Channel Power MOSFET

Features

- ◆ Low $R_{DS(on)}$ & FOM
- ◆ Extremely low switching loss
- ◆ Excellent stability and uniformity
- ◆ Easy to drive

Applications





- ◆ Lighting
- ◆ Hard switching PWM
- ◆ Server power supply
- ◆ Charger

■ General Description

OSG60R150xF use advanced GreenMOST™ technology to provide low $R_{DS(ON)}$, low gate charge, fast switching and excellent avalanche characteristics. This device is suitable for active power factor correction and switching mode power supply applications.

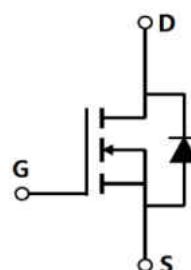
| | |
|-----------------------------------|--------|
| ◆ $V_{DS, min@T_{jmax}}$ | 650 V |
| ◆ $I_D, pulse$ | 69 A |
| ◆ $R_{DS(ON), max @ V_{GS}=10 V}$ | 150 mΩ |
| ◆ Q_g | 23 nC |

■ Schematic and Package Information

| SCHEMATIC DIAGRAM | PIN ASSIGNMENT-TOP VIEW | | | |
|--|--|--|---|---|
|  |  TO220F OSG60R150FF |  TO220 OSG60R150PF |  TO263 OSG60R150KF |  TO247 OSG60R150HF |

■ Absolute Maximum Ratings at $T_j=25^\circ\text{C}$ unless otherwise noted

| Parameter | Symbol | Value | Unit |
|---|----------------|------------|------------------|
| Drain source voltage | V_{DS} | 600 | V |
| Gate source voltage | V_{GS} | ± 30 | V |
| Continuous drain current ¹⁾ , $T_C=25^\circ\text{C}$ | I_D | 23 | A |
| Continuous drain current ¹⁾ , $T_C=100^\circ\text{C}$ | | 14.5 | |
| Pulsed drain current ²⁾ , $T_C=25^\circ\text{C}$ | $I_{D, pulse}$ | 69 | A |
| Power dissipation ³⁾ for TO220, TO263, TO247, $T_C=25^\circ\text{C}$ | P_D | 151 | W |
| Power dissipation ³⁾ for TO220F, $T_C=25^\circ\text{C}$ | | 34 | |
| Single pulsed avalanche energy ⁵⁾ | E_{AS} | 600 | mJ |
| MOSFET dv/dt ruggedness, $V_{DS}=0\text{...}480\text{ V}$ | dv/dt | 50 | V/ns |
| Reverse diode dv/dt, $V_{DS}=0\text{...}480\text{ V}$, $I_{SD}\leq I_D$ | dv/dt | 15 | V/ns |
| Operation and storage temperature | T_{stg}, T_j | -55 to 150 | $^\circ\text{C}$ |

■ Thermal Characteristics

| Parameter | Symbol | Value | | Unit |
|--|-----------------|-------------------|--------|------|
| | | TO220/TO263/TO247 | TO220F | |
| Thermal resistance, junction-case | $R_{\theta JC}$ | 0.82 | 3.67 | °C/W |
| Thermal resistance, junction-ambient ⁴⁾ | $R_{\theta JA}$ | 62 | 62.5 | °C/W |

■ Electrical Characteristics at $T_j=25\text{ }^\circ\text{C}$ unless otherwise specified

| Parameter | Symbol | Min. | Typ. | Max. | Unit | Test condition |
|----------------------------------|--------------|------|------|------|---------------|---|
| Drain-source breakdown voltage | BV_{DSS} | 600 | | | V | $V_{GS}=0\text{ V}$, $I_D=250\text{ }\mu\text{A}$ |
| | | 650 | 716 | | | $V_{GS}=0\text{ V}$, $I_D=250\text{ }\mu\text{A}$, $T_j=150\text{ }^\circ\text{C}$ |
| Gate threshold voltage | $V_{GS(th)}$ | 2.0 | | 4.0 | V | $V_{DS}=V_{GS}$, $I_D=250\text{ }\mu\text{A}$ |
| Drain-source on-state resistance | $R_{DS(on)}$ | | 0.12 | 0.15 | Ω | $V_{GS}=10\text{ V}$, $I_D=10\text{ A}$ |
| | | | 0.29 | | | $V_{GS}=10\text{ V}$, $I_D=10\text{ A}$, $T_j=150\text{ }^\circ\text{C}$ |
| Gate-source leakage current | I_{GSS} | | | 100 | nA | $V_{GS}=30\text{ V}$ |
| | | | | -100 | | $V_{GS}=-30\text{ V}$ |
| Drain-source leakage current | I_{DSS} | | | 1 | μA | $V_{DS}=600\text{ V}$, $V_{GS}=0\text{ V}$ |

■ Dynamic Characteristics

| Parameter | Symbol | Min. | Typ. | Max. | Unit | Test condition |
|------------------------------|--------------|------|------|------|------|--|
| Input capacitance | C_{iss} | | 1356 | | pF | $V_{GS}=0\text{ V}$, $V_{DS}=50\text{ V}$, $f=1\text{ MHz}$ |
| Output capacitance | C_{oss} | | 155 | | pF | |
| Reverse transfer capacitance | C_{rss} | | 2 | | pF | |
| Turn-on delay time | $t_{d(on)}$ | | 38.2 | | ns | $V_{GS}=10\text{ V}$, $V_{DS}=400\text{ V}$, $R_G=25\text{ }\Omega$, $I_D=10\text{ A}$ |
| Rise time | t_r | | 25.2 | | ns | |
| Turn-off delay time | $t_{d(off)}$ | | 79.2 | | ns | |
| Fall time | t_f | | 31.5 | | ns | |

■ Gate Charge Characteristics

| Parameter | Symbol | Min. | Typ. | Max. | Unit | Test condition |
|----------------------|----------------------|------|------|------|------|--|
| Total gate charge | Q_g | | 23 | | nC | $I_D=10\text{ A}$, $V_{DS}=400\text{ V}$, $V_{GS}=10\text{ V}$ |
| Gate-source charge | Q_{gs} | | 6.0 | | nC | |
| Gate-drain charge | Q_{gd} | | 8.3 | | nC | |
| Gate plateau voltage | V_{plateau} | | 5.6 | | V | |

■ Body Diode Characteristics

| Parameter | Symbol | Min. | Typ. | Max. | Unit | Test condition |
|-------------------------------|-----------|------|-------|------|---------------|--|
| Diode forward current | I_S | | | 23 | A | $V_{GS} < V_{th}$ |
| Pulsed source current | I_{SP} | | | 69 | | |
| Diode forward voltage | V_{SD} | | | 1.4 | V | $I_S=23\text{ A}$, $V_{GS}=0\text{ V}$ |
| Reverse recovery time | t_{rr} | | 258.1 | | ns | $V_R=400\text{ V}$, $I_S=10\text{ A}$, $di/dt=100\text{ A}/\mu\text{s}$ |
| Reverse recovery charge | Q_{rr} | | 2.8 | | μC | |
| Peak reverse recovery current | I_{rrm} | | 19 | | A | |

■ Note

- 1) Calculated continuous current based on maximum allowable junction temperature.
- 2) Repetitive rating; pulse width limited by max. junction temperature.
- 3) P_d is based on max. junction temperature, using junction-case thermal resistance.
- 4) The value of $R_{\theta JA}$ is measured with the device mounted on 1 in 2 FR-4 board with 2oz. Copper, in a still air environment with $T_a=25\text{ }^\circ\text{C}$.
- 5) $V_{DD}=100\text{ V}$, $R_G=25\text{ }\Omega$, $L=10.8\text{ mH}$, starting $T_j=25\text{ }^\circ\text{C}$.

■ **Electrical Characteristics Diagrams**

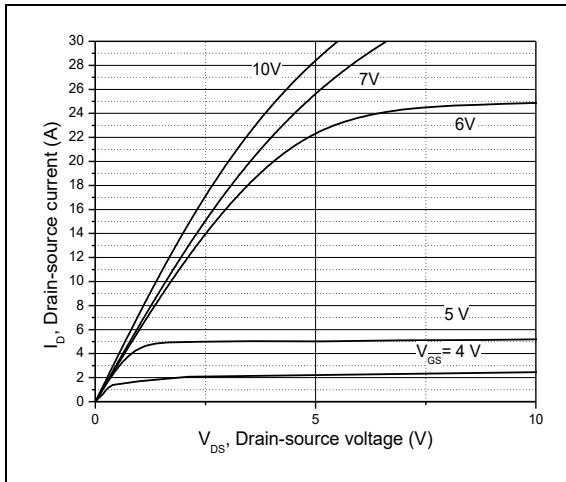

Figure 1, Typ. output characteristics

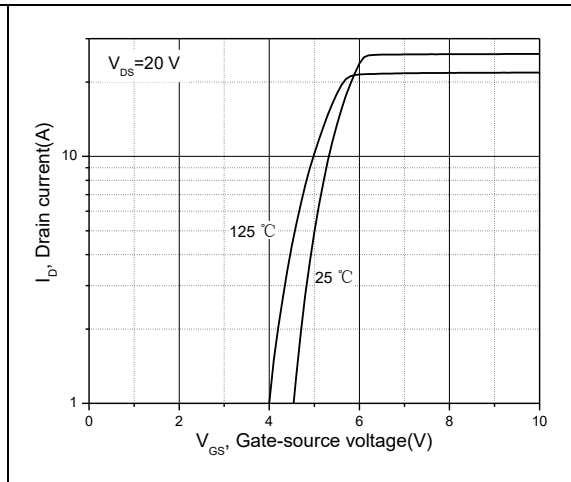

Figure 2, Typ. transfer characteristics

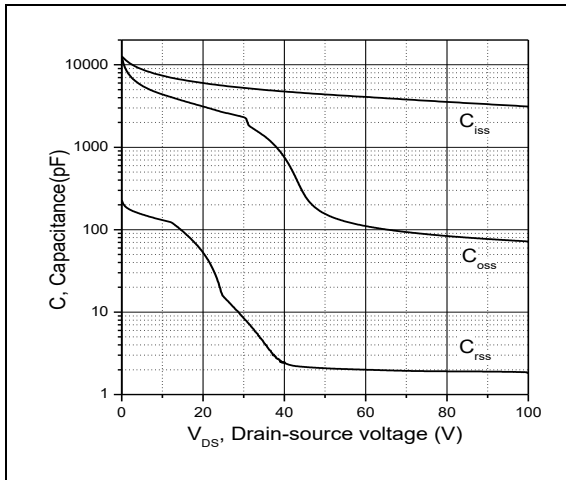

Figure 3, Typ. capacitances

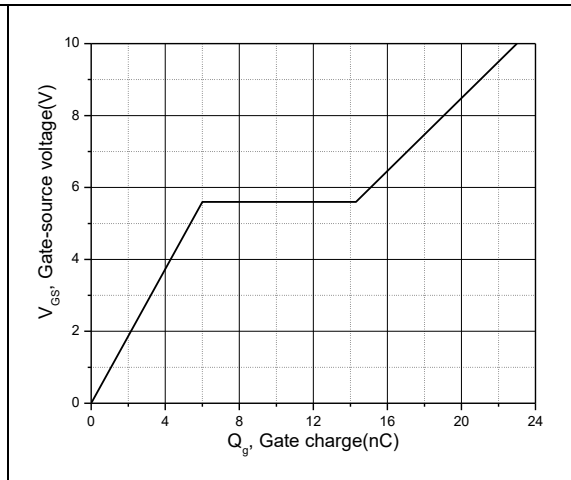

Figure 4, Typ. gate charge

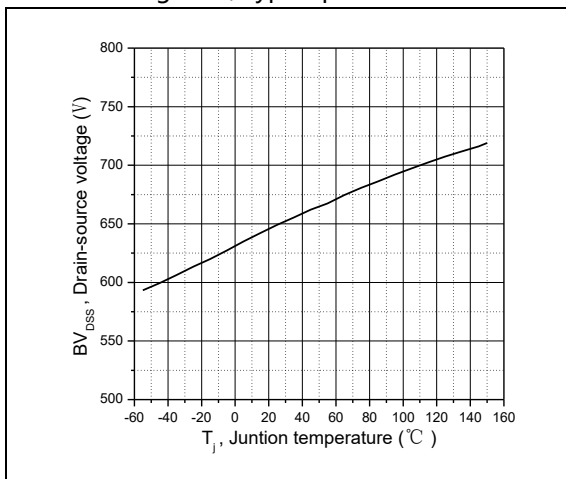

Figure 5, Drain-source breakdown voltage

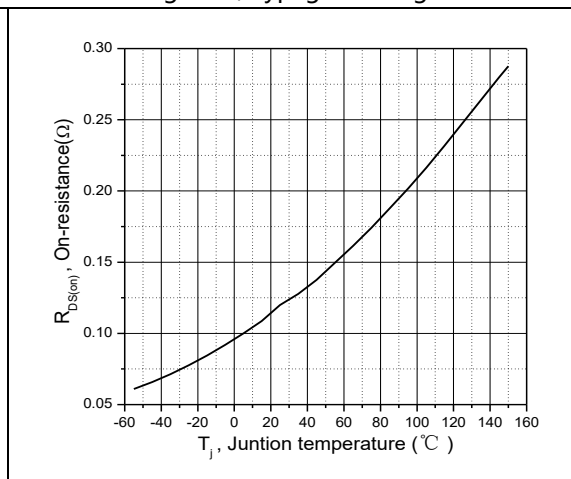

Figure 6, Drain-source on-state resistance

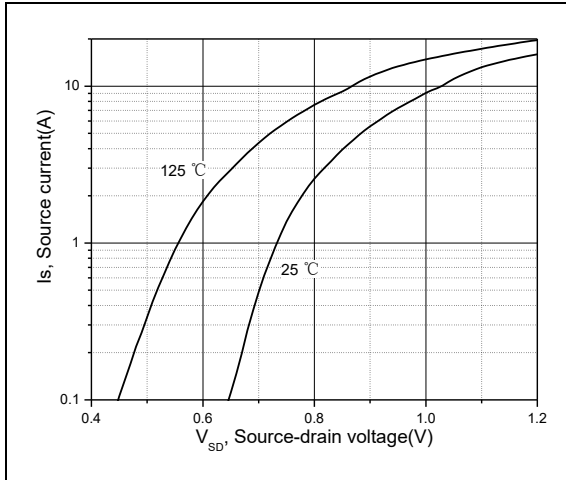

Figure 7, Forward characteristic of body diode

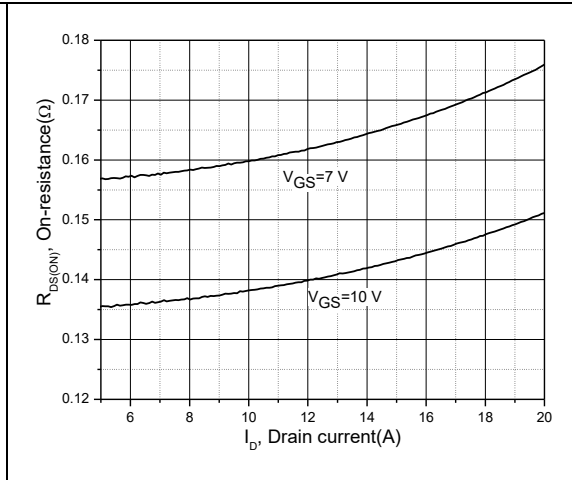

Figure 8, Drain-source on-state resistance

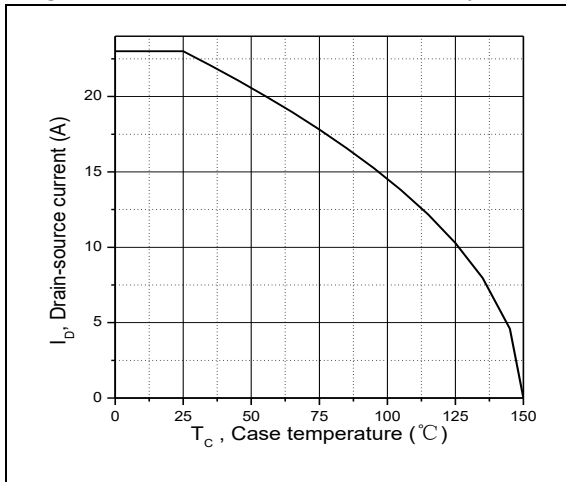

Figure 9, Drain current

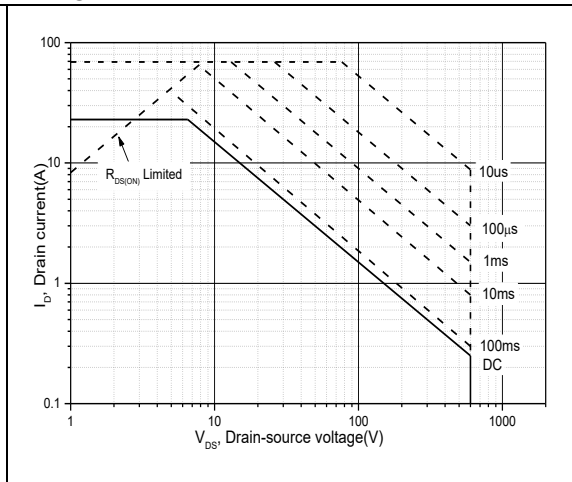

Figure 10, Safe operation area for TO220/TO263/TO247 $T_C=25\text{ }^\circ\text{C}$

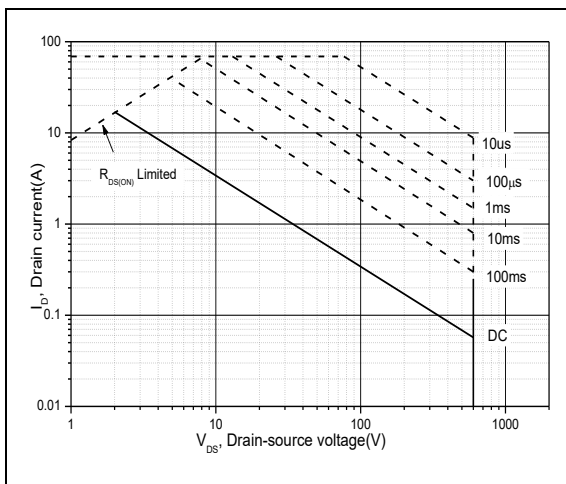

Figure 11, Safe operation area for TO220F $T_C=25\text{ }^\circ\text{C}$

■ Test circuits and waveforms

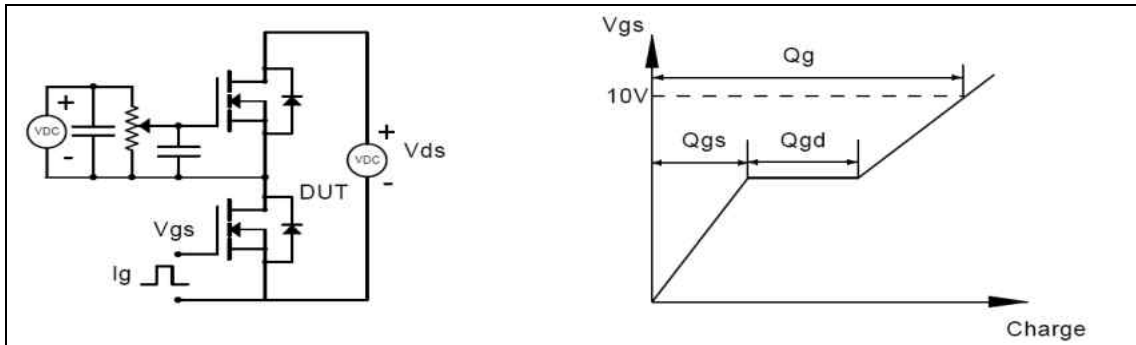

Figure 1, Gate charge test circuit & waveform

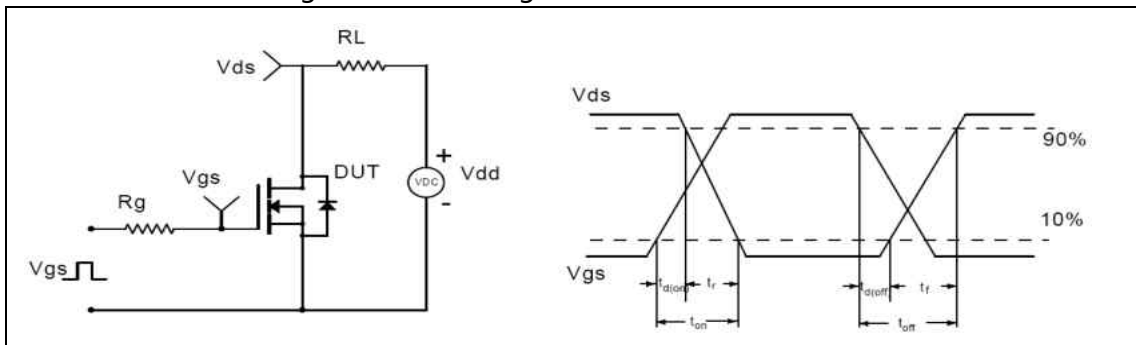

Figure 2, Switching time test circuit & waveforms

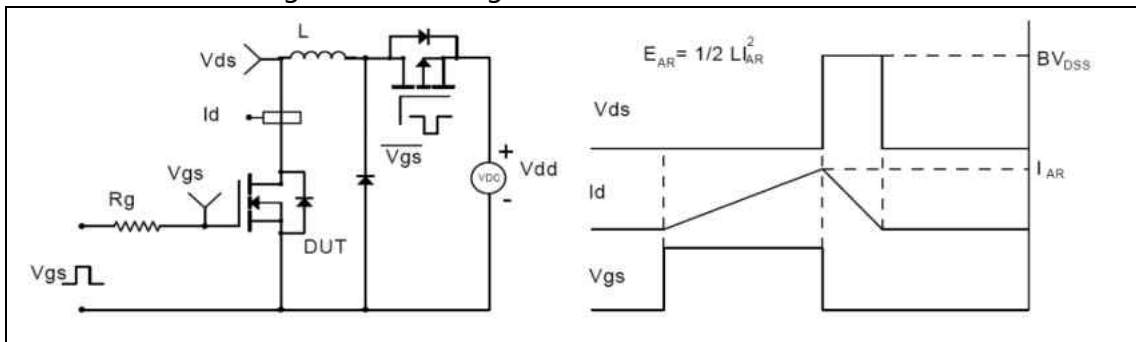

Figure 3, Unclamped inductive switching (UIS) test circuit & waveforms

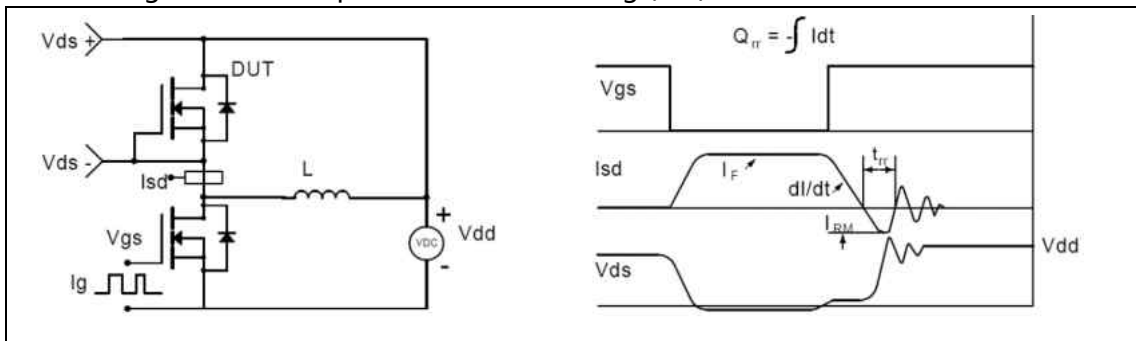
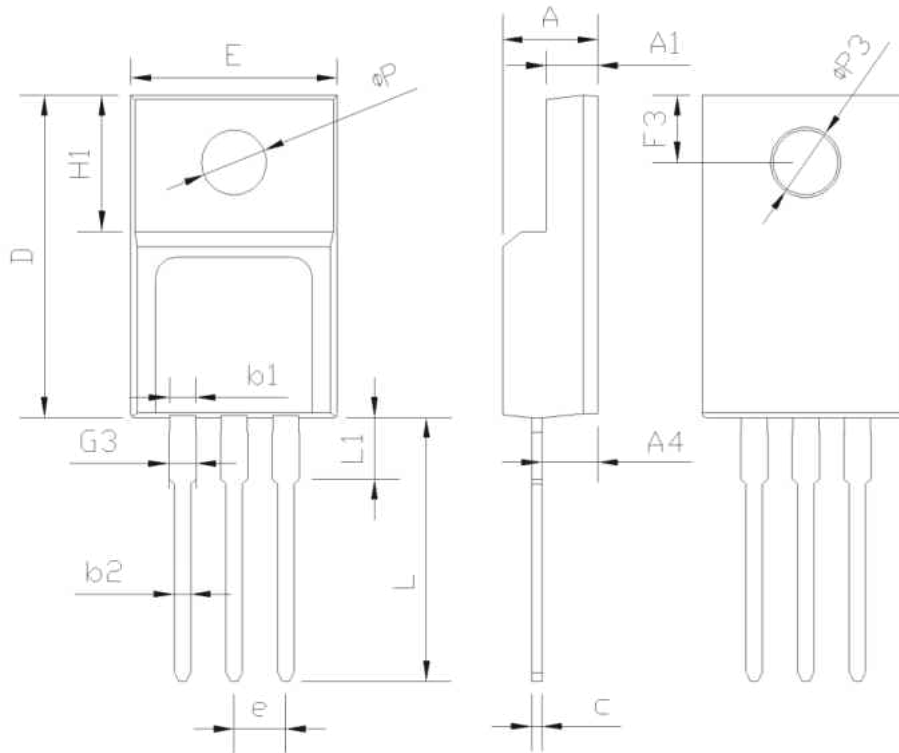

Figure 4, Diode reverse recovery test circuit & waveforms

■ Package Information

Figure1, TO220F package outline dimension



| SYMBOL | mm | | |
|--------|---------|-------|-------|
| | MIN | NOM | MAX |
| E | 9.96 | 10.16 | 10.36 |
| A | 4.50 | 4.70 | 4.90 |
| A1 | 2.34 | 2.54 | 2.74 |
| A4 | 2.56 | 2.76 | 2.96 |
| c | 0.40 | 0.50 | 0.65 |
| D | 15.57 | 15.87 | 16.17 |
| H1 | 6.70REF | | |
| e | 2.54BSC | | |
| L | 12.68 | 12.98 | 13.28 |
| L1 | 2.88 | 3.03 | 3.18 |
| ΦP | 3.03 | 3.18 | 3.38 |
| ΦP3 | 3.15 | 3.45 | 3.65 |
| F3 | 3.15 | 3.30 | 3.45 |
| G3 | 1.25 | 1.35 | 1.55 |
| b1 | 1.18 | 1.28 | 1.43 |
| b2 | 0.70 | 0.80 | 0.95 |

■ Package Information

Figure2, TO220 package outline dimension

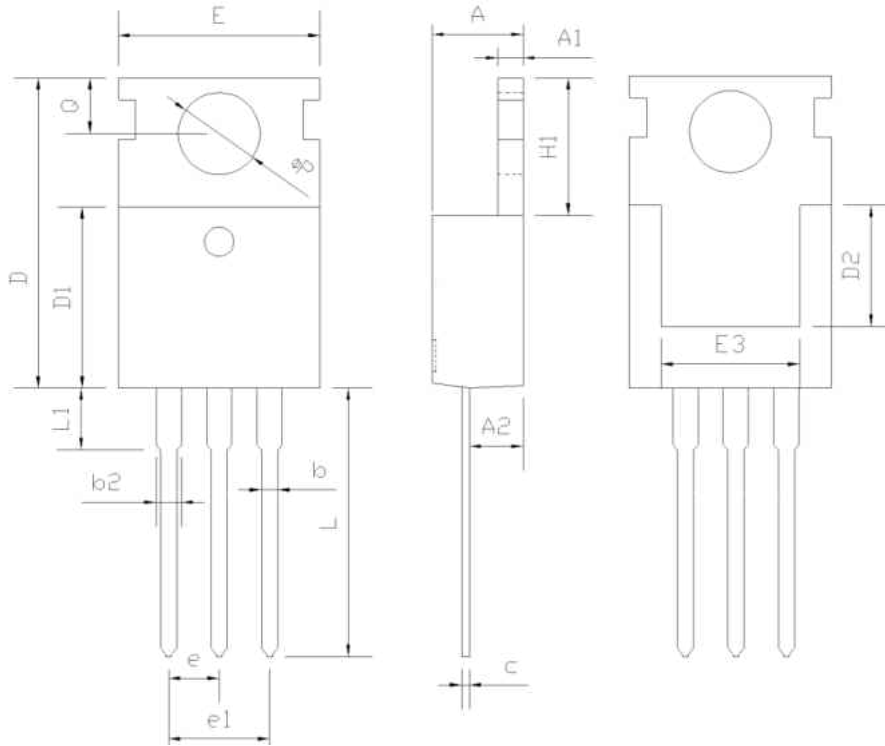

| SYMBOL | mm | | |
|--------|----------|-------|-------|
| | MIN | NOM | MAX |
| A | 4.37 | 4.57 | 4.70 |
| A1 | 1.25 | 1.30 | 1.40 |
| A2 | 2.20 | 2.40 | 2.60 |
| b | 0.70 | 0.80 | 0.95 |
| b2 | 1.17 | 1.27 | 1.47 |
| c | 0.45 | 0.50 | 0.60 |
| D | 15.10 | 15.60 | 16.10 |
| D1 | 8.80 | 9.10 | 9.40 |
| D2 | 5.50 | - | - |
| E | 9.70 | 10.00 | 10.30 |
| E3 | 7.00 | - | - |
| e | 2.54 BSC | | |
| e1 | 5.08 BSC | | |
| H1 | 6.25 | 6.50 | 6.85 |
| L | 12.75 | 13.50 | 13.80 |
| L1 | - | 3.10 | 3.40 |
| ΦP | 3.40 | 3.60 | 3.80 |
| Q | 2.60 | 2.80 | 3.00 |

■ Package Information

Figure3, TO263 package outline dimension

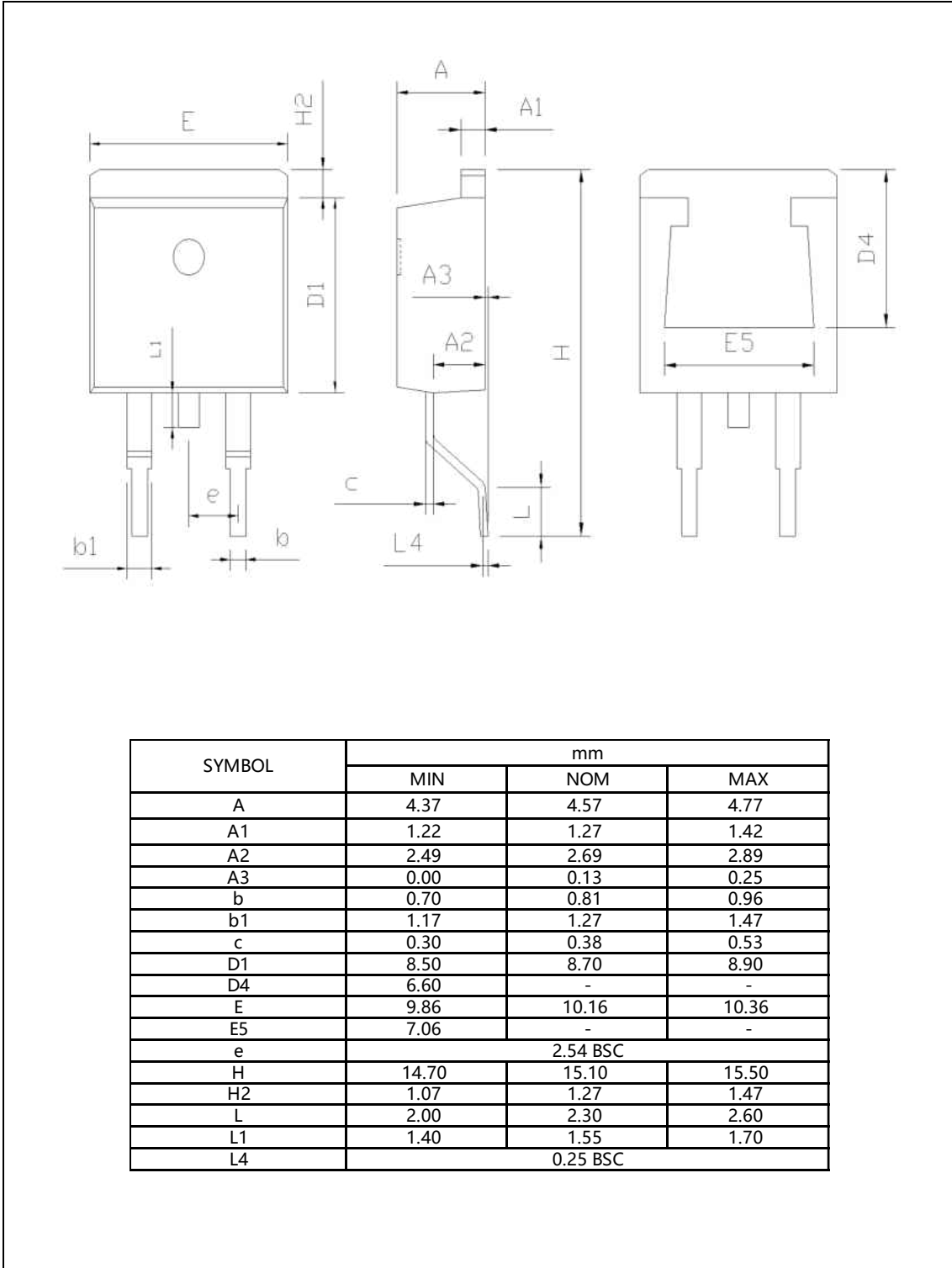

■ Package Information

Figure4, TO247 package outline dimension

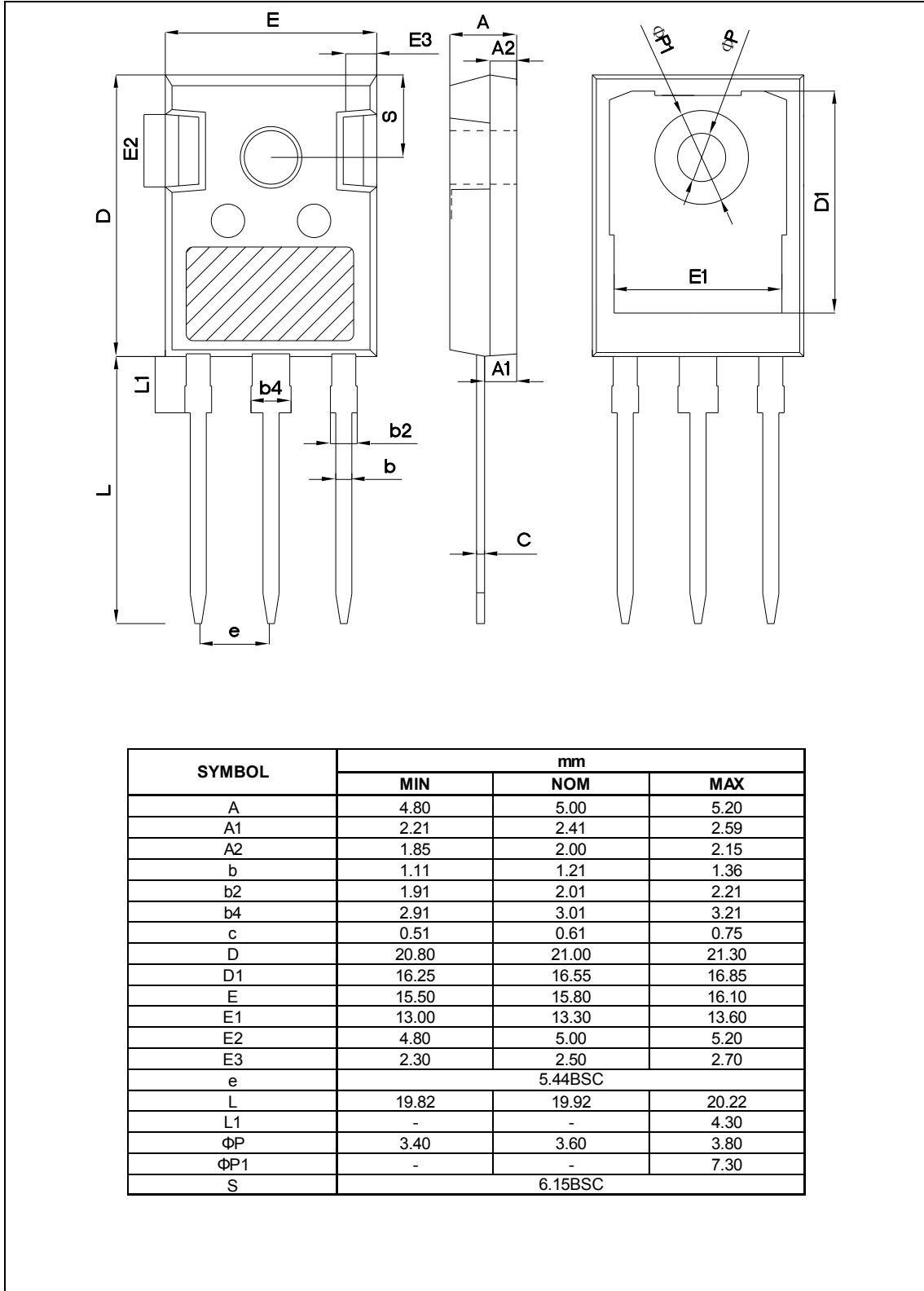

■ Ordering Information

| Package | Units/Tube | Tubes/Inner Box | Units/Inner Box | Inner Box/Carton Box | Units/Carton Box |
|---------|------------|-----------------|-----------------|----------------------|------------------|
| TO220F | 50 | 20 | 1000 | 6 | 6000 |
| TO220 | 50 | 20 | 1000 | 6 | 6000 |
| TO263 | 50 | 20 | 1000 | 6 | 6000 |
| TO247 | 30 | 11 | 330 | 6 | 1980 |

■ Product Information

| Product | Package | Pb Free | RoHS | Halogen Free |
|-------------|---------|---------|------|--------------|
| OSG60R150FF | TO220F | yes | yes | yes |
| OSG60R150PF | TO220 | yes | yes | yes |
| OSG60R150KF | TO263 | yes | yes | yes |
| OSG60R150HF | TO247 | yes | yes | yes |