

OSG65R099xZF_Datasheet

Enhancement Mode N-Channel Power MOSFET

Features

- ◆ Ultra-fast and robust body diode
- ◆ Low $R_{DS(on)}$ & FOM
- ◆ Excellent low switching loss
- ◆ Excellent stability and uniformity
- ◆ Easy to drive

Applications

- ◆ PC power
- ◆ Server power supply
- ◆ Telecom
- ◆ Solar inverter
- ◆ Super charger for automobiles

■ General Description

OSG65R099xZF use advanced GreenMOSTM technology to provide low $R_{DS(ON)}$, low gate charge, fast switching and excellent avalanche characteristics. This device offers extremely fast and robust body diode, and is suitable for telecom and super charger applications.

◆ $V_{DS, min@T_{jmax}}$	700 V
◆ $I_{D, pulse}$	96 A
◆ $R_{DS(ON), max @ V_{GS}=10 V}$	99 mΩ
◆ Q_g	42.6 nC

■ Schematic and Package Information



■ Absolute Maximum Ratings at $T_j=25^\circ\text{C}$ unless otherwise noted

Parameter	Symbol	Value	Unit
Drain source voltage	V_{DS}	650	V
Gate source voltage	V_{GS}	± 30	V
Continuous drain current ¹⁾ , $T_C=25^\circ\text{C}$	I_D	32	A
Continuous drain current ¹⁾ , $T_C=100^\circ\text{C}$		20	
Pulsed drain current ²⁾ , $T_C=25^\circ\text{C}$	$I_{D, pulse}$	96	A
Power dissipation ³⁾ for TO247, $T_C=25^\circ\text{C}$	P_D	278	W
Power dissipation ³⁾ for TO220F, $T_C=25^\circ\text{C}$		35	
Single pulsed avalanche energy ⁵⁾	E_{AS}	1000	mJ
MOSFET dv/dt ruggedness, $V_{DS}=0\dots 480\text{ V}$	dv/dt	100	V/ns
Reverse diode dv/dt, $V_{DS}=0\dots 480\text{ V}$, $I_{SD}\leq I_D$	dv/dt	50	V/ns
Operation and storage temperature	T_{stg}, T_j	-55 to 150	$^\circ\text{C}$

■ Thermal Characteristics

Parameter	Symbol	Value		Unit
		TO247	TO220F	
Thermal resistance, junction-case	$R_{\theta JC}$	0.45	3.6	°C/W
Thermal resistance, junction-ambient ⁴⁾	$R_{\theta JA}$	62	62.5	°C/W

■ Electrical Characteristics at $T_j=25\text{ }^\circ\text{C}$ unless otherwise specified

Parameter	Symbol	Min.	Typ.	Max.	Unit	Test condition
Drain-source breakdown voltage	BV_{DSS}	650			V	$V_{GS}=0\text{ V}$, $I_D=1\text{ mA}$
		700	770			$V_{GS}=0\text{ V}$, $I_D=1\text{ mA}$ $T_j=150\text{ }^\circ\text{C}$
Gate threshold voltage	$V_{GS(th)}$	3.5		4.5	V	$V_{DS}=V_{GS}$, $I_D=1\text{ mA}$
Drain-source on-state resistance	$R_{DS(on)}$		0.090	0.099	Ω	$V_{GS}=10\text{ V}$, $I_D=16\text{ A}$
			0.23			$V_{GS}=10\text{ V}$, $I_D=16\text{ A}$, $T_j=150\text{ }^\circ\text{C}$
Gate-source leakage current	I_{GSS}			100	nA	$V_{GS}=30\text{ V}$
				-100		$V_{GS}=-30\text{ V}$
Drain-source leakage current	I_{DSS}			10	μA	$V_{DS}=650\text{ V}$, $V_{GS}=0\text{ V}$

■ Dynamic Characteristics

Parameter	Symbol	Min.	Typ.	Max.	Unit	Test condition
Input capacitance	C_{iss}		3073		pF	$V_{GS}=0\text{ V}$, $V_{DS}=50\text{ V}$, $f=1\text{ MHz}$
Output capacitance	C_{oss}		448.8		pF	
Reverse transfer capacitance	C_{rss}		7.3		pF	
Turn-on delay time	$t_{d(on)}$		36.6		ns	$V_{GS}=10\text{ V}$, $V_{DS}=400\text{ V}$, $R_G=2\text{ }\Omega$, $I_D=20\text{ A}$
Rise time	t_r		57.4		ns	
Turn-off delay time	$t_{d(off)}$		39.6		ns	
Fall time	t_f		3.6		ns	

■ Gate Charge Characteristics

Parameter	Symbol	Min.	Typ.	Max.	Unit	Test condition
Total gate charge	Q_g		42.5		nC	$I_D=20\text{ A}$, $V_{DS}=400\text{ V}$, $V_{GS}=10\text{ V}$
Gate-source charge	Q_{gs}		14		nC	
Gate-drain charge	Q_{gd}		12.2		nC	
Gate plateau voltage	V_{plateau}		6.0		V	

■ Body Diode Characteristics

Parameter	Symbol	Min.	Typ.	Max.	Unit	Test condition
Diode forward current	I_S			32	A	$V_{GS} < V_{th}$
Pulsed source current	I_{SP}			96		
Diode forward voltage	V_{SD}			1.4	V	$I_S=32\text{ A}$, $V_{GS}=0\text{ V}$
Reverse recovery time	t_{rr}		162		ns	$I_S=20\text{ A}$, $di/dt=100\text{ A}/\mu\text{s}$
Reverse recovery charge	Q_{rr}		1.12		μC	
Peak reverse recovery current	I_{rrm}		13		A	

■ Note

- 1) Calculated continuous current based on maximum allowable junction temperature.
- 2) Repetitive rating; pulse width limited by max. junction temperature.
- 3) P_d is based on max. junction temperature, using junction-case thermal resistance.
- 4) The value of $R_{\theta JA}$ is measured with the device mounted on 1 in 2 FR-4 board with 2oz. Copper, in a still air environment with $T_a=25\text{ }^\circ\text{C}$.
- 5) $V_{DD}=100\text{ V}$, $R_G=25\text{ }\Omega$, $L=80\text{ mH}$, starting $T_j=25\text{ }^\circ\text{C}$.

■ **Electrical Characteristics Diagrams**

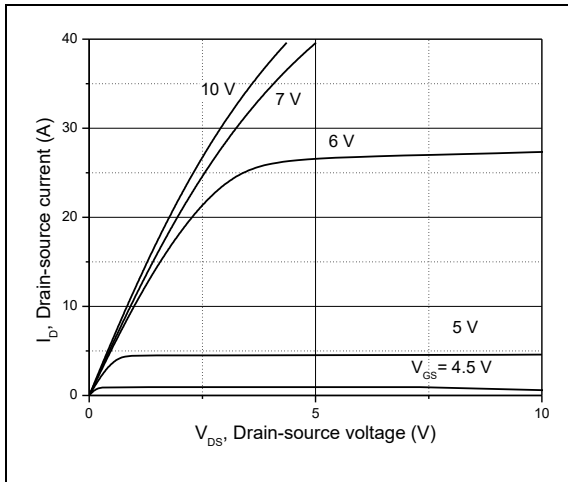

Figure 1, Typ. output characteristics

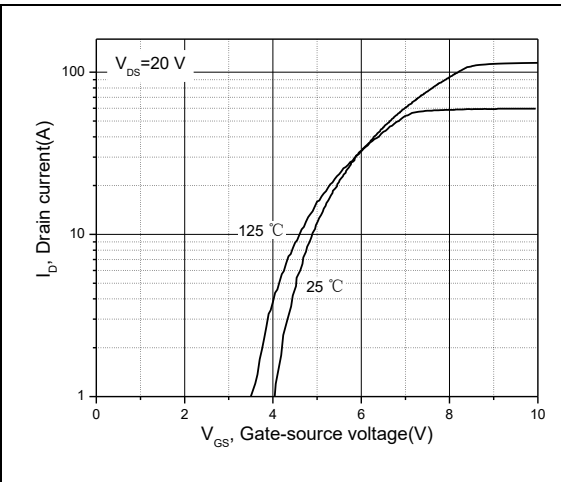

Figure 2, Typ. transfer characteristics

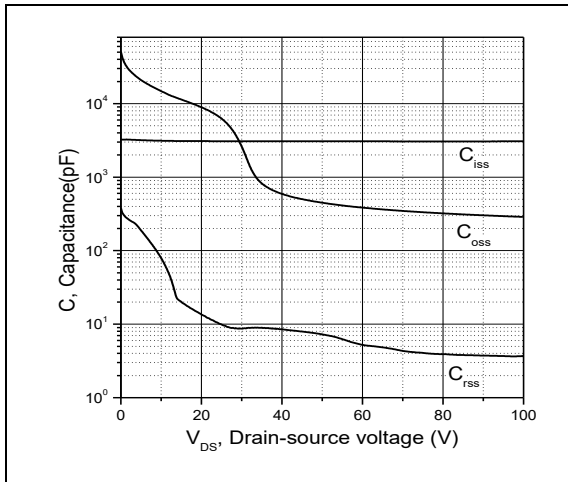

Figure 3, Typ. capacitances

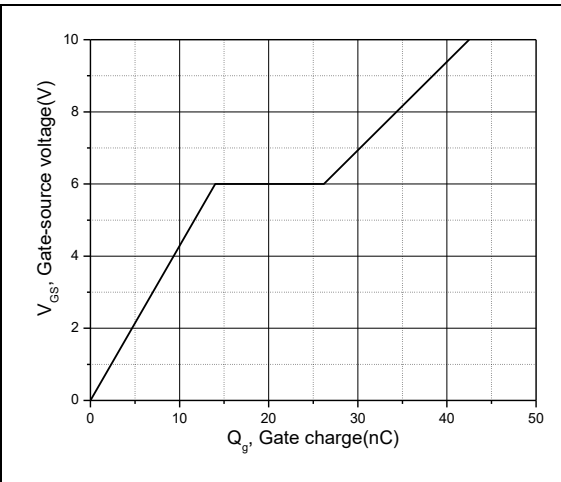

Figure 4, Typ. gate charge

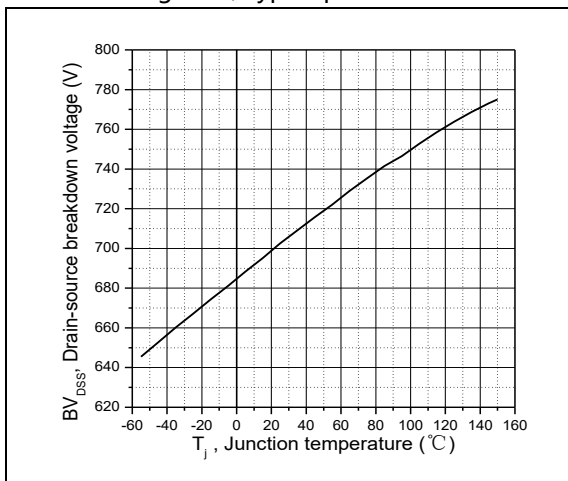

Figure 5, Drain-source breakdown voltage

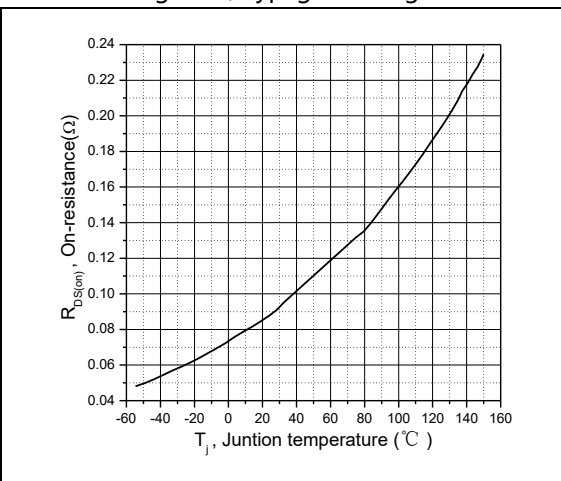

Figure 6, Drain-source on-state resistance

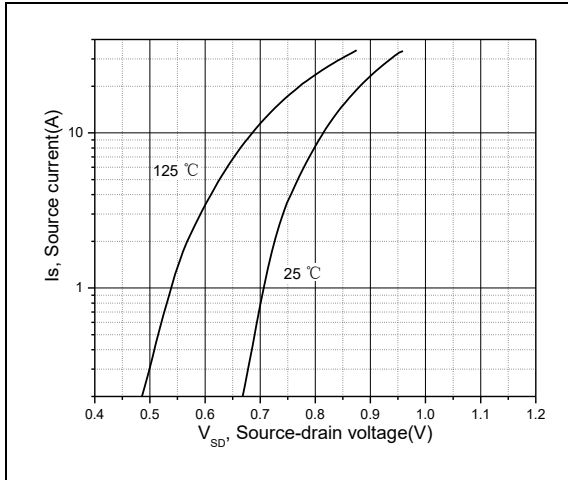

Figure 7, Forward characteristic of body diode

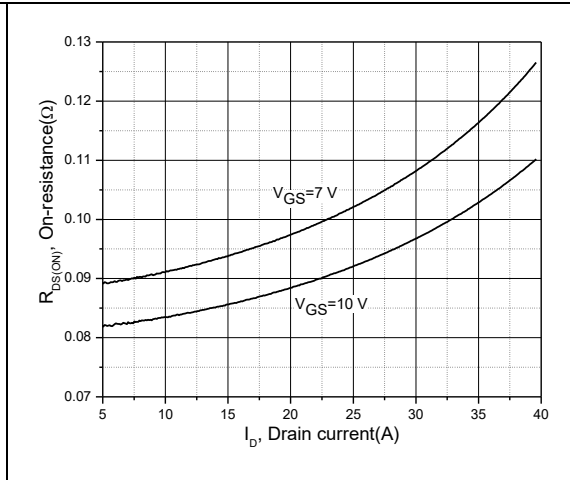

Figure 8, Drain-source on-state resistance

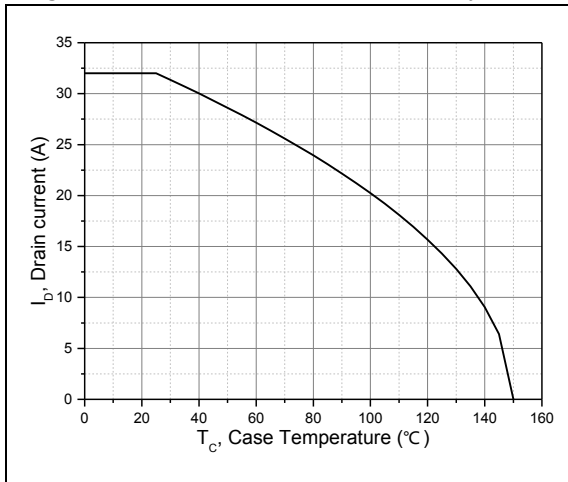

Figure 9, Drain current

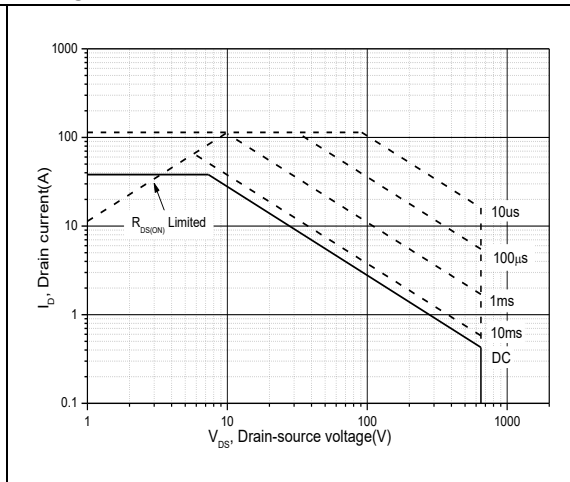

Figure 10, Safe operation area for TO247,
 $T_C = 25\text{ °C}$

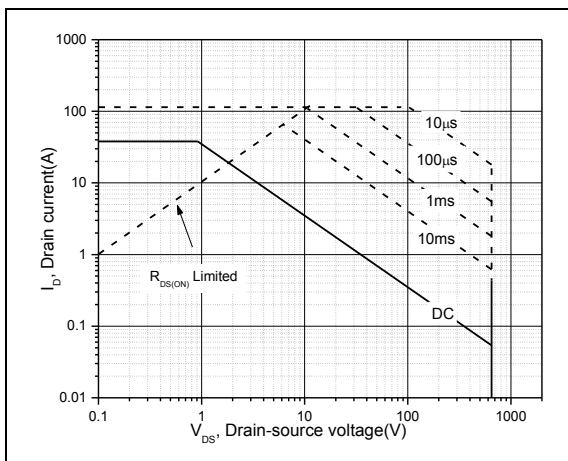

Figure 11, Safe operation area for TO220F,
 $T_C = 25\text{ °C}$

■ Test circuits and waveforms

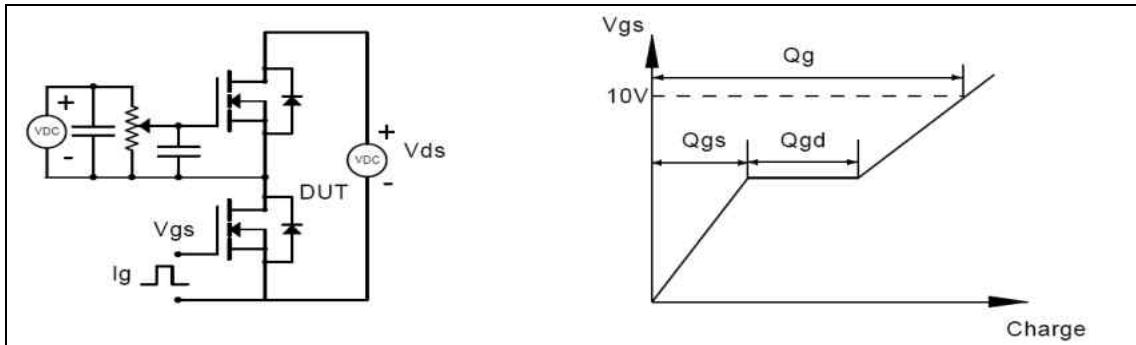

Figure 1, Gate charge test circuit & waveform

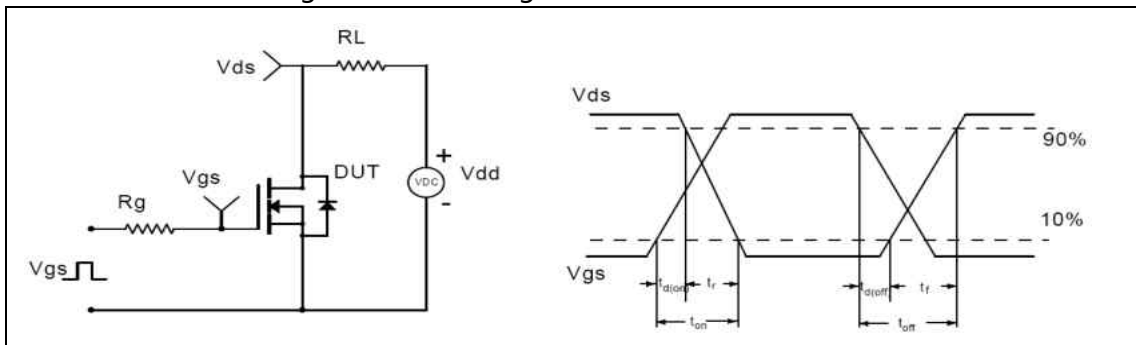

Figure 2, Switching time test circuit & waveforms

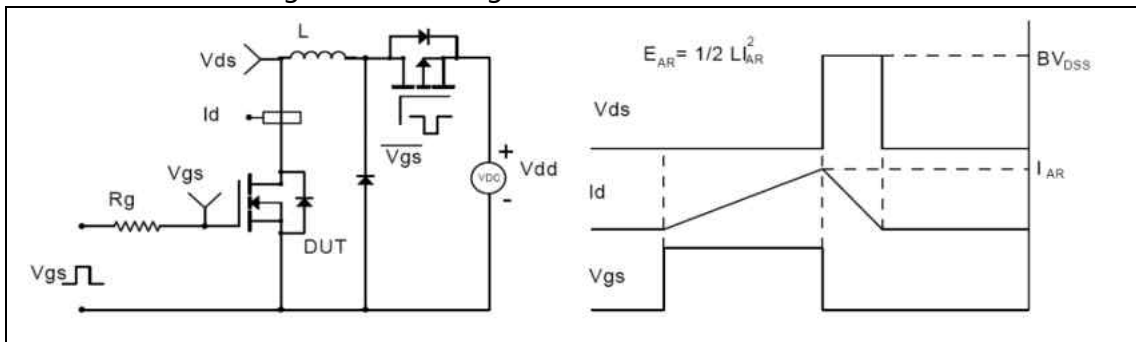

Figure 3, Unclamped inductive switching (UIS) test circuit & waveforms

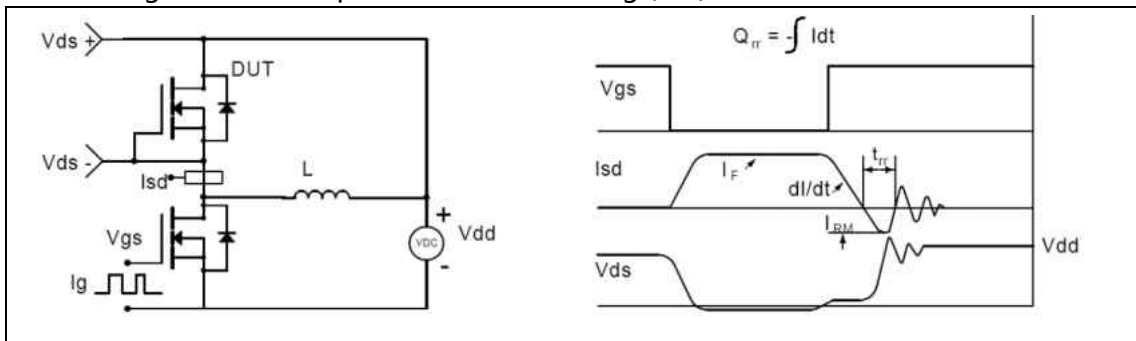
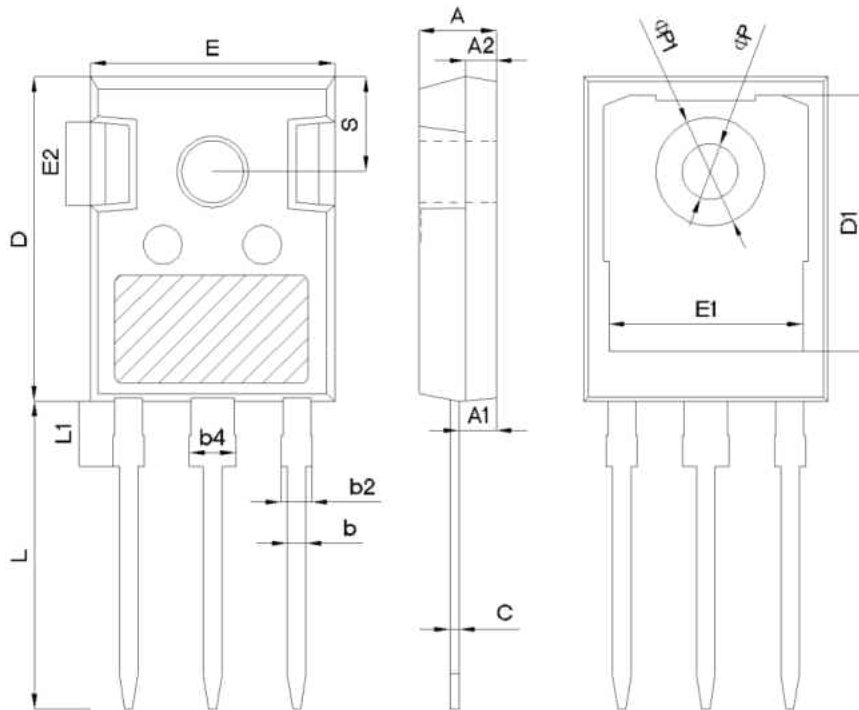

Figure 4, Diode reverse recovery test circuit & waveforms

■ Package Information

Figure1, TO247 package outline dimension



SYMBOL	mm		
	MIN	NOM	MAX
A	4.80	5.00	5.20
A1	2.21	2.41	2.61
A2	1.85	2.00	2.15
b	1.11	1.21	1.36
b2	1.91	2.01	2.21
b4	2.91	3.01	3.21
c	0.51	0.61	0.75
D	20.70	21.00	21.30
D1	16.25	16.55	16.85
E	15.50	15.80	16.10
E1	13.00	13.30	13.60
E2	4.80	5.00	5.20
E3	2.30	2.50	2.70
e	5.44BSC		
L	19.62	19.92	20.22
L1	-	-	4.30
ΦP	3.40	3.60	3.80
ΦP1	-	-	7.30
S	6.15BSC		

■ Package Information

Figure2, TO220F package outline dimension

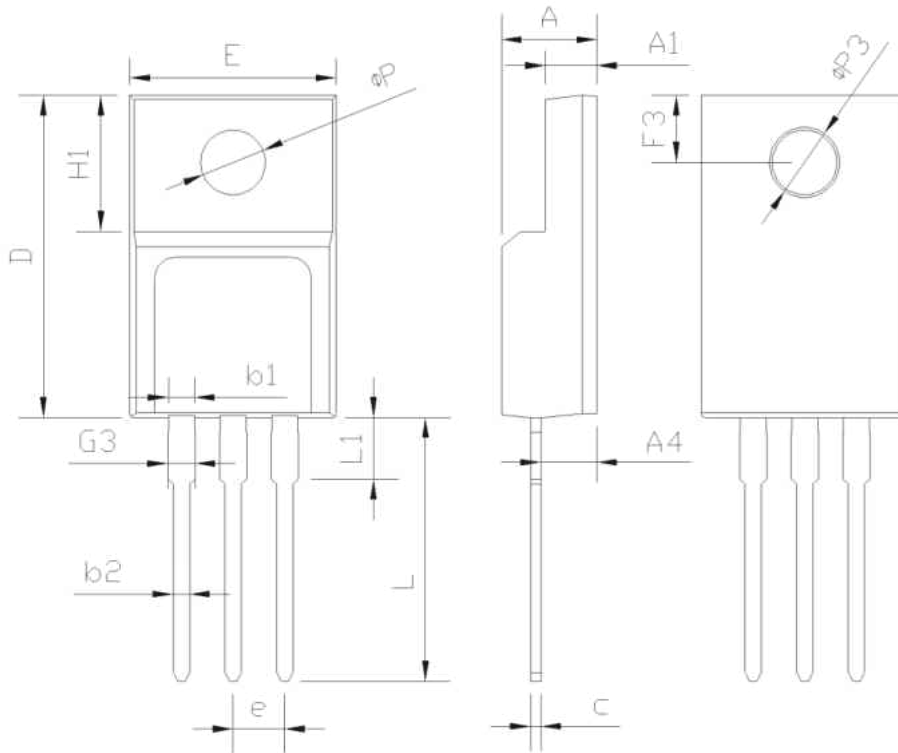

SYMBOL	mm		
	MIN	NOM	MAX
E	9.96	10.16	10.36
A	4.50	4.70	4.90
A1	2.34	2.54	2.74
A2	0.30	0.45	0.60
A4	2.56	2.76	2.96
c	0.40	0.50	0.65
c1	1.20	1.30	1.35
D	15.57	15.87	16.17
H1	6.70REF		
e	2.54BSC		
L	12.68	12.98	13.28
L1	2.88	3.03	3.18
ΦP	3.03	3.18	3.38
ΦP3	3.15	3.45	3.65
F3	3.15	3.30	3.45
G3	1.25	1.35	1.55
b1	1.18	1.28	1.43
b2	0.70	0.80	0.95

■ Ordering Information

Package	Units/Tube	Tubes/Inner Box	Units/Inner Box	Inner Box/Carton Box	Units/Carton Box
TO247	30	11	330	6	1980
TO220F	50	20	1000	6	6000

■ Product Information

Product	Package	Pb Free	RoHS	Halogen Free
OSG65R099HZF	TO247	yes	yes	yes
OSG65R099FZF	TO247	yes	yes	yes