

Enhancement Mode N-Channel Power MOSFET

Features

- ◆ Low $R_{DS(on)}$ & FOM
- ◆ Extremely low switching loss
- ◆ Excellent stability and uniformity
- ◆ Easy to drive

Applications





- ◆ Lighting
- ◆ Hard switching PWM
- ◆ Server power supply
- ◆ Charger

■ General Description

OSG65R200xF use advanced GreenMOST™ technology to provide low $R_{DS(ON)}$, low gate charge, fast switching and excellent avalanche characteristics. This device is suitable for active power factor correction and switching mode power supply applications.

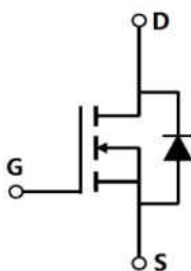
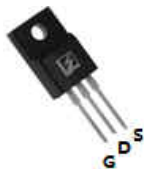
◆ $V_{DS, min@Tjmax}$	700 V
◆ $I_{D, pulse}$	60 A
◆ $R_{DS(ON), max @ V_{GS}=10 V}$	200 mΩ
◆ Q_g	24.8 nC

■ Schematic and Package Information

SCHEMATIC DIAGRAM	PIN ASSIGNMENT-TOP VIEW			
	 TO220F OSG65R200FF	 TO220 OSG65R200PF	 TO263 OSG65R200KF	 TO247 OSG65R200HF

■ Absolute Maximum Ratings at $T_j=25^\circ\text{C}$ unless otherwise noted

Parameter	Symbol	Value	Unit
Drain source voltage	V_{DS}	650	V
Gate source voltage	V_{GS}	± 30	V
Continuous drain current ¹⁾ , $T_C=25^\circ\text{C}$	I_D	20	A
Continuous drain current ¹⁾ , $T_C=100^\circ\text{C}$		12.5	
Pulsed drain current ²⁾ , $T_C=25^\circ\text{C}$	$I_{D, pulse}$	60	A
Power dissipation ³⁾ for TO263, TO247, TO220, $T_C=25^\circ\text{C}$	P_D	151	W
Power dissipation ³⁾ for TO220F, $T_C=25^\circ\text{C}$		34	
Single pulsed avalanche energy ⁵⁾	E_{AS}	600	mJ
Single pulsed avalanche current ⁵⁾	I_{AS}	10.9	A
Repetitive avalanche energy	E_{AR}	0.8	mJ
Repetitive avalanche current	I_{AR}	10.9	A
MOSFET dv/dt ruggedness, $V_{DS}=0\dots 480\text{ V}$	dv/dt	50	V/ns
Reverse diode dv/dt, $V_{DS}=0\dots 480\text{ V}$, $I_{SD}\leq I_D$	dv/dt	15	V/ns
Operation and storage temperature	T_{stg}, T_j	-55 to 150	$^\circ\text{C}$

■ Thermal Characteristics

Parameter	Symbol	Value		Unit
		TO220/TO263/TO247	TO220F	
Thermal resistance, junction-case	$R_{\theta JC}$	0.82	3.67	°C/W
Thermal resistance, junction-ambient ⁴⁾	$R_{\theta JA}$	62	62.5	°C/W

■ Electrical Characteristics at $T_j=25\text{ }^\circ\text{C}$ unless otherwise specified

Parameter	Symbol	Min.	Typ.	Max.	Unit	Test condition
Drain-source breakdown voltage	BV_{DSS}	650			V	$V_{GS}=0\text{ V}$, $I_D=250\text{ }\mu\text{A}$
		700	774			$V_{GS}=0\text{ V}$, $I_D=250\text{ }\mu\text{A}$, $T_j=150\text{ }^\circ\text{C}$
Gate threshold voltage	$V_{GS(th)}$	2.0		4.0	V	$V_{DS}=V_{GS}$, $I_D=250\text{ }\mu\text{A}$
Drain-source on-state resistance	$R_{DS(on)}$		0.16	0.2	Ω	$V_{GS}=10\text{ V}$, $I_D=10\text{ A}$
			0.42			$V_{GS}=10\text{ V}$, $I_D=10\text{ A}$, $T_j=150\text{ }^\circ\text{C}$
Gate-source leakage current	I_{GSS}			100	nA	$V_{GS}=30\text{ V}$
				-100		$V_{GS}=-30\text{ V}$
Drain-source leakage current	I_{DSS}			1	μA	$V_{DS}=650\text{ V}$, $V_{GS}=0\text{ V}$

■ Dynamic Characteristics

Parameter	Symbol	Min.	Typ.	Max.	Unit	Test condition
Input capacitance	C_{iss}		1433		pF	$V_{GS}=0\text{ V}$, $V_{DS}=50\text{ V}$, $f=1\text{ MHz}$
Output capacitance	C_{oss}		92.5		pF	
Reverse transfer capacitance	C_{rss}		3.9		pF	
Turn-on delay time	$t_{d(on)}$		40.1		ns	$V_{GS}=10\text{ V}$, $V_{DS}=520\text{ V}$, $R_G=25\text{ }\Omega$, $I_D=20\text{ A}$
Rise time	t_r		49.8		ns	
Turn-off delay time	$t_{d(off)}$		57.3		ns	
Fall time	t_f		63.7		ns	



■ Gate Charge Characteristics

Parameter	Symbol	Min.	Typ.	Max.	Unit	Test condition
Total gate charge	Q_g		24.8		nC	$I_D=20\text{ A}$, $V_{DS}=520\text{ V}$, $V_{GS}=10\text{ V}$
Gate-source charge	Q_{gs}		7.2		nC	
Gate-drain charge	Q_{gd}		8.2		nC	
Gate plateau voltage	V_{plateau}		5.6		V	

■ Body Diode Characteristics

Parameter	Symbol	Min.	Typ.	Max.	Unit	Test condition
Diode forward current	I_S			20	A	$V_{GS}<V_{th}$
Pulsed source current	I_{SP}			60		
Diode forward voltage	V_{SD}			1.4	V	$I_S=20\text{ A}$, $V_{GS}=0\text{ V}$
Reverse recovery time	t_{rr}		380		ns	$V_R=400\text{ V}$, $I_S=20\text{ A}$, $di/dt=100\text{ A}/\mu\text{s}$
Reverse recovery charge	Q_{rr}		5.3		μC	
Peak reverse recovery current	I_{rrm}		25.7		A	

■ Note

- 1) Calculated continuous current based on maximum allowable junction temperature.
- 2) Repetitive rating; pulse width limited by max. junction temperature.
- 3) P_d is based on max. junction temperature, using junction-case thermal resistance.
- 4) The value of $R_{\theta JA}$ is measured with the device mounted on 1 in 2 FR-4 board with 2oz. Copper, in a still air environment with $T_a=25\text{ }^\circ\text{C}$.
- 5) $V_{DD}=150\text{ V}$, $R_G=25\text{ }\Omega$, $L=10.8\text{ mH}$, starting $T_j=25\text{ }^\circ\text{C}$.



Electrical Characteristics Diagrams

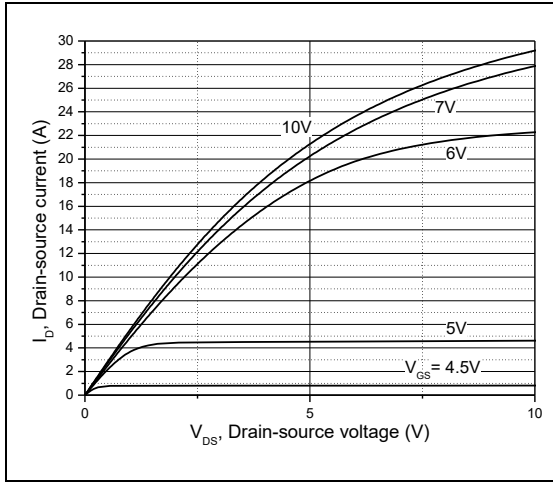

Figure 1, Typ. output characteristics

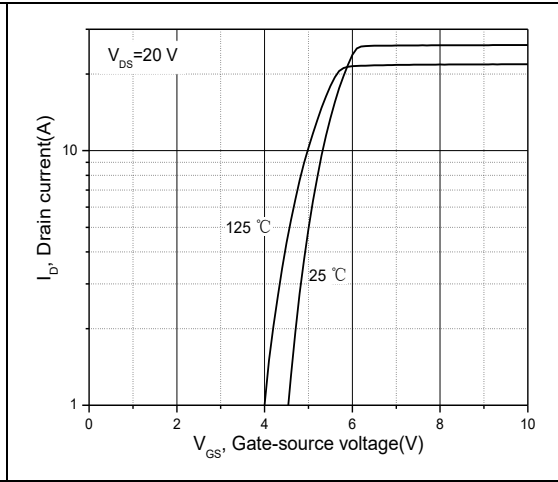

Figure 2, Typ. transfer characteristics

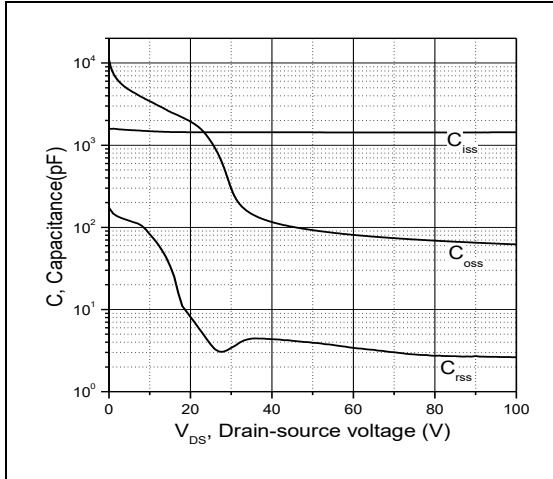

Figure 3, Typ. capacitances

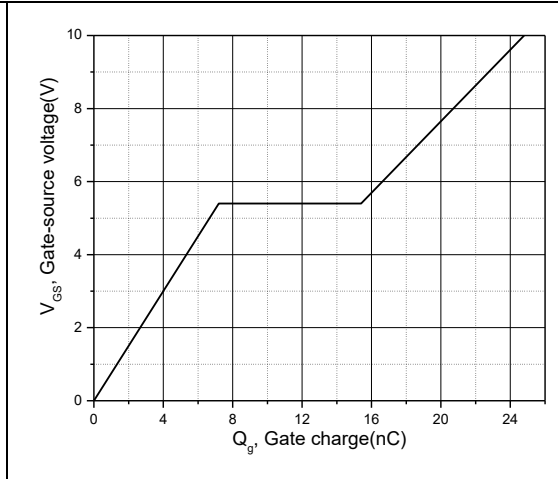

Figure 4, Typ. gate charge

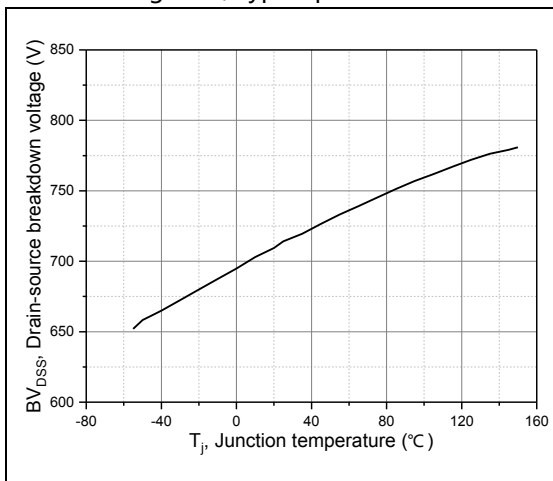

Figure 5, Drain-source breakdown voltage

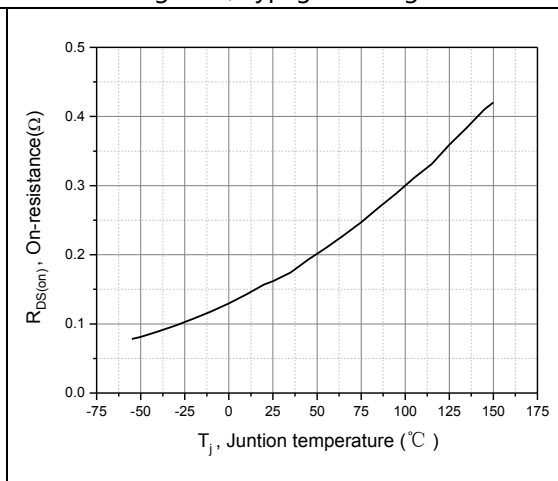

Figure 6, Drain-source on-state resistance

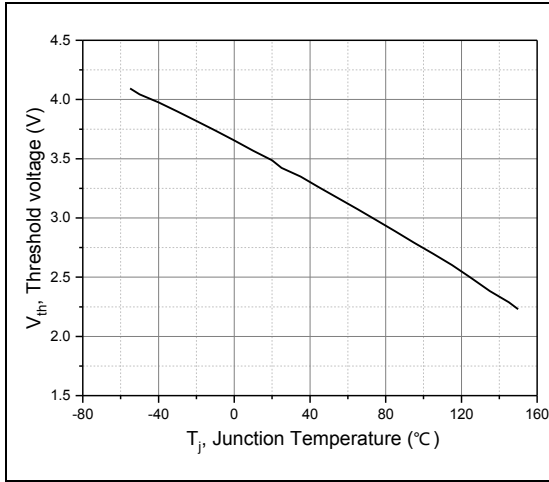

Figure 7, Threshold voltage

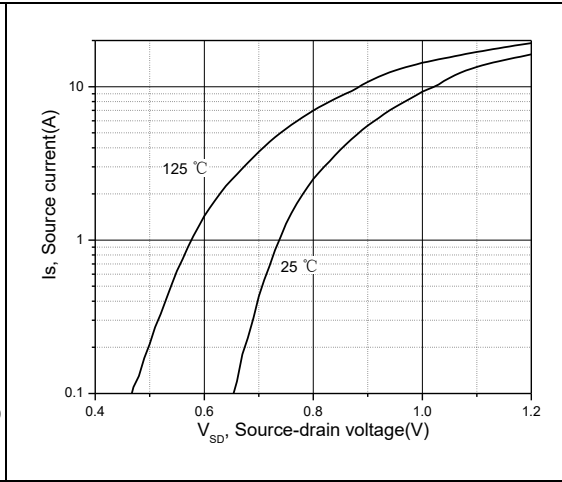

Figure 8, Forward characteristic of body diode

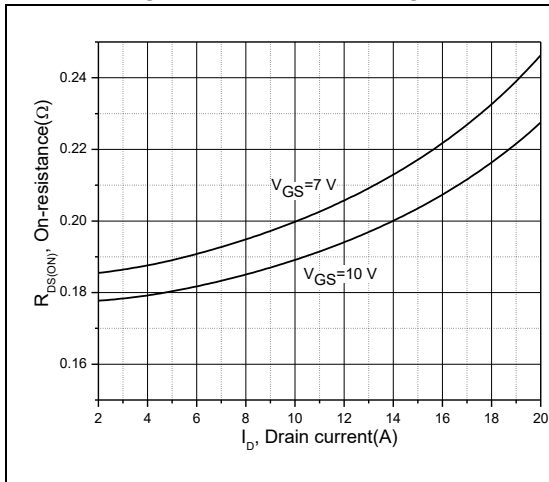

Figure 9, Drain-source on-state resistance

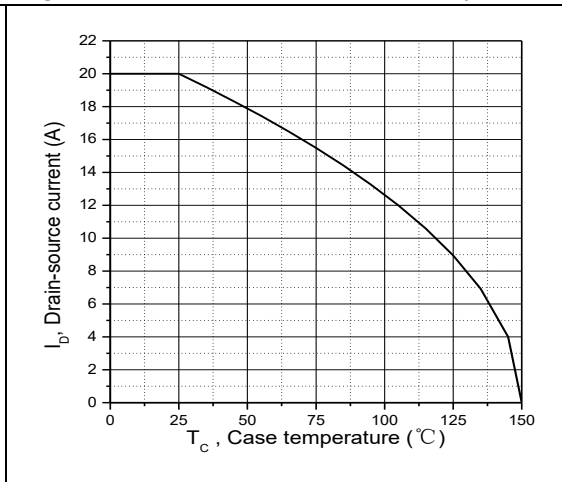

Figure 10, Drain current

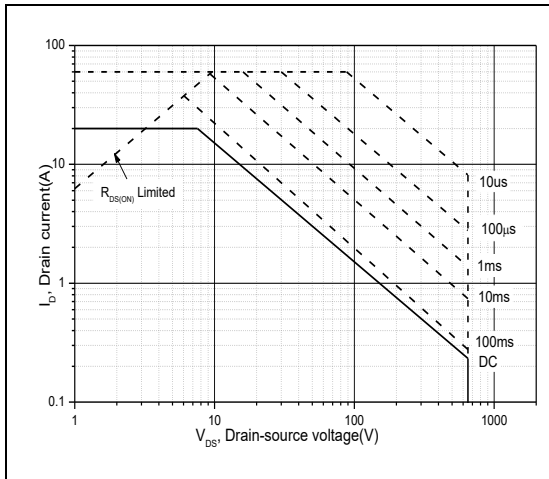

Figure 11, Safe operation area for TO220/TO263/TO247 $T_C=25\text{ }^\circ\text{C}$

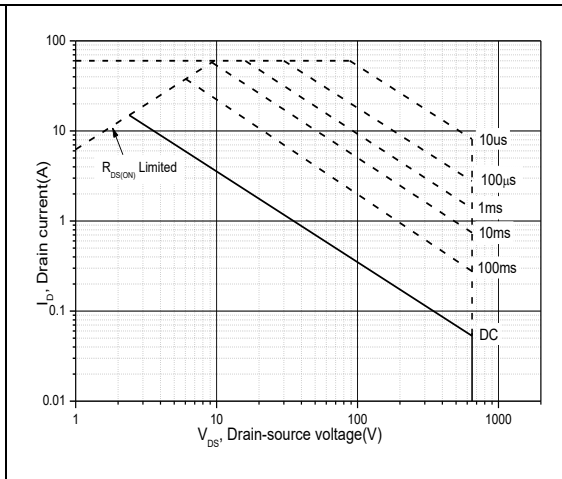
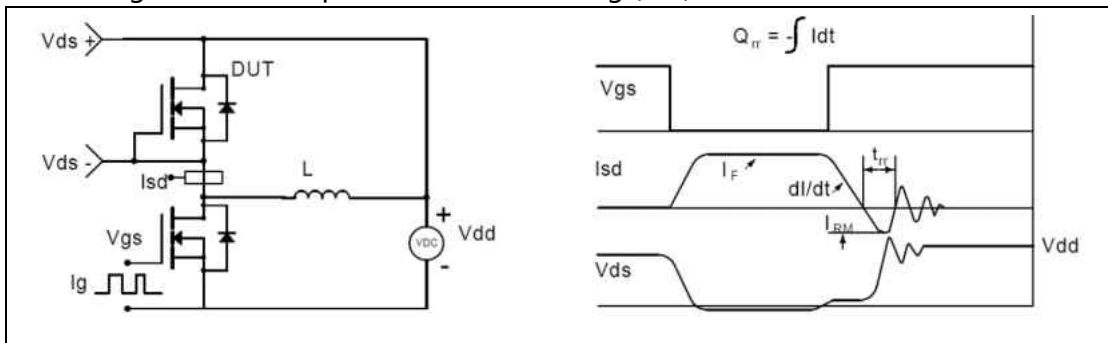
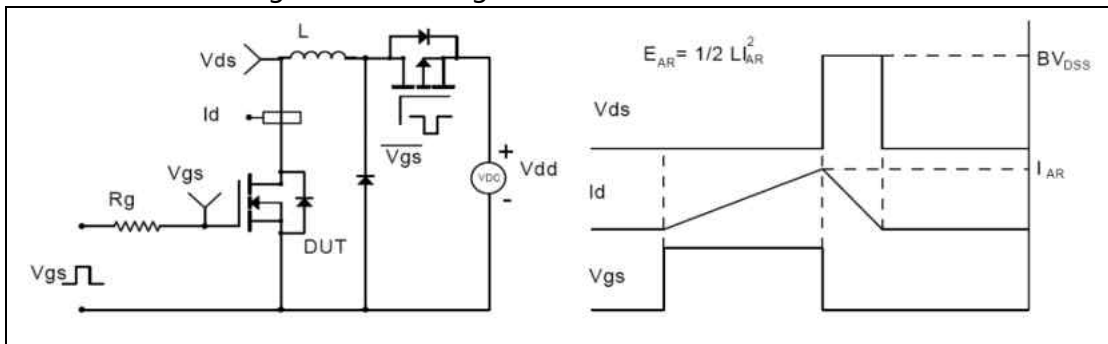
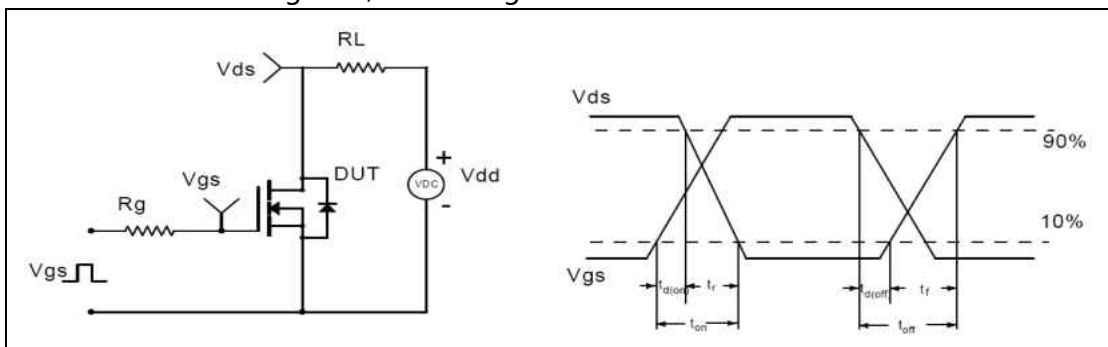
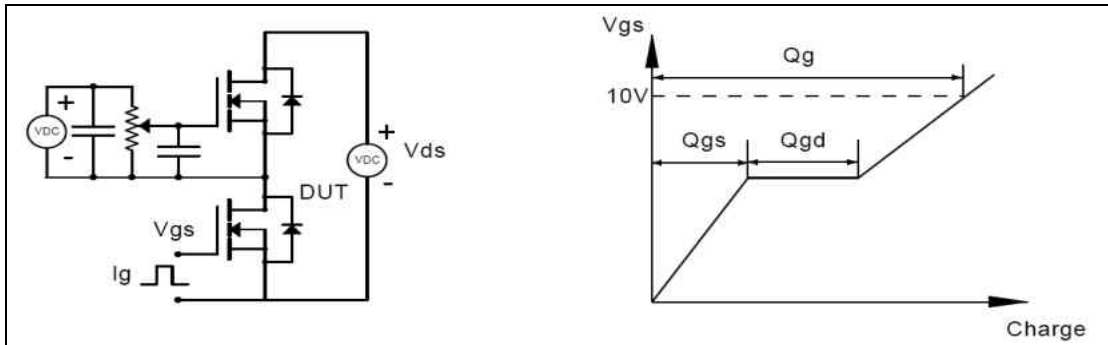

Figure 12, Safe operation area for TO220F $T_C=25\text{ }^\circ\text{C}$



■ Test circuits and waveforms





■ Package Information

Figure1, TO220F package outline dimension

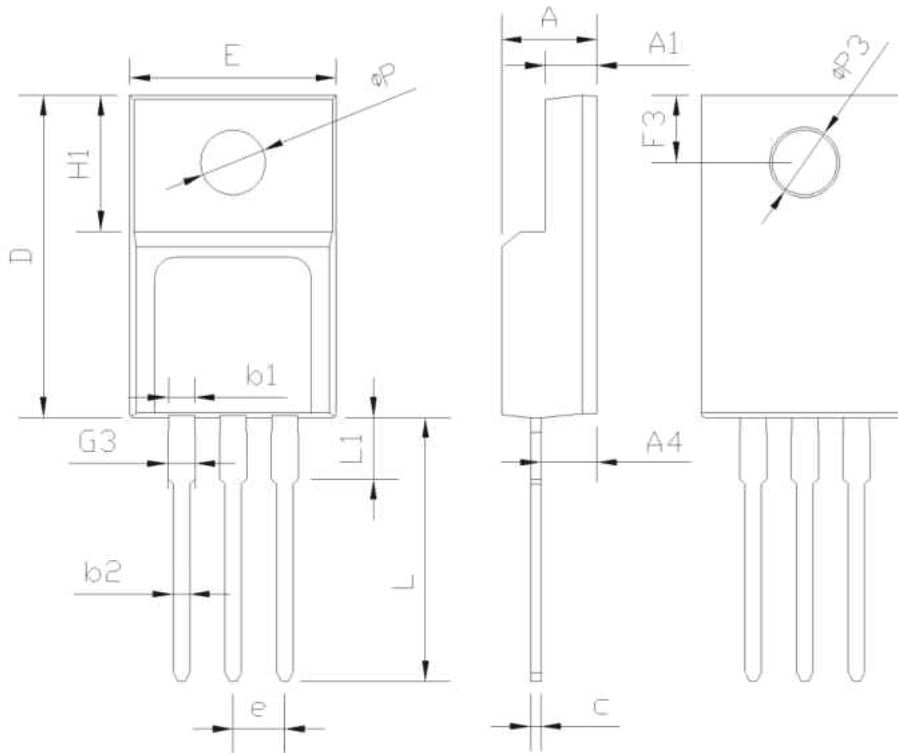

SYMBOL	mm		
	MIN	NOM	MAX
E	9.96	10.16	10.36
A	4.50	4.70	4.90
A1	2.34	2.54	2.74
A4	2.56	2.76	2.96
c	0.40	0.50	0.65
D	15.57	15.87	16.17
H1	6.70REF		
e	2.54BSC		
L	12.68	12.98	13.28
L1	2.88	3.03	3.18
ΦP	3.03	3.18	3.38
ΦP3	3.15	3.45	3.65
F3	3.15	3.30	3.45
G3	1.25	1.35	1.55
b1	1.18	1.28	1.43
b2	0.70	0.80	0.95



■ Package Information

Figure2, TO220 package outline dimension

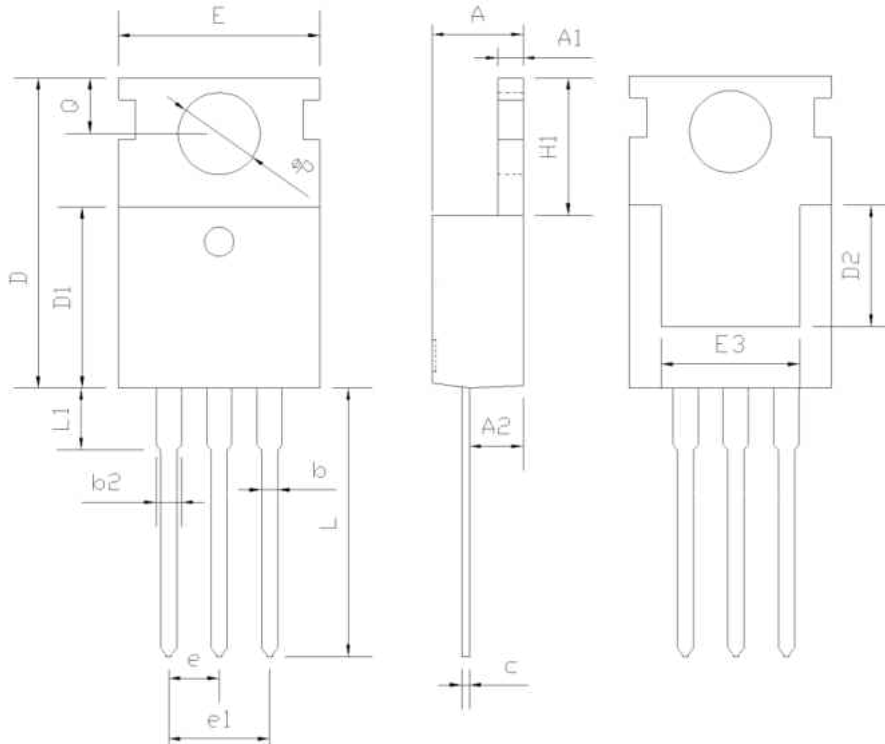

SYMBOL	mm		
	MIN	NOM	MAX
A	4.37	4.57	4.70
A1	1.25	1.30	1.40
A2	2.20	2.40	2.60
b	0.70	0.80	0.95
b2	1.17	1.27	1.47
c	0.45	0.50	0.60
D	15.10	15.60	16.10
D1	8.80	9.10	9.40
D2	5.50	-	-
E	9.70	10.00	10.30
E3	7.00	-	-
e	2.54 BSC		
e1	5.08 BSC		
H1	6.25	6.50	6.85
L	12.75	13.50	13.80
L1	-	3.10	3.40
ΦP	3.40	3.60	3.80
Q	2.60	2.80	3.00



■ Package Information

Figure3, TO263 package outline dimension

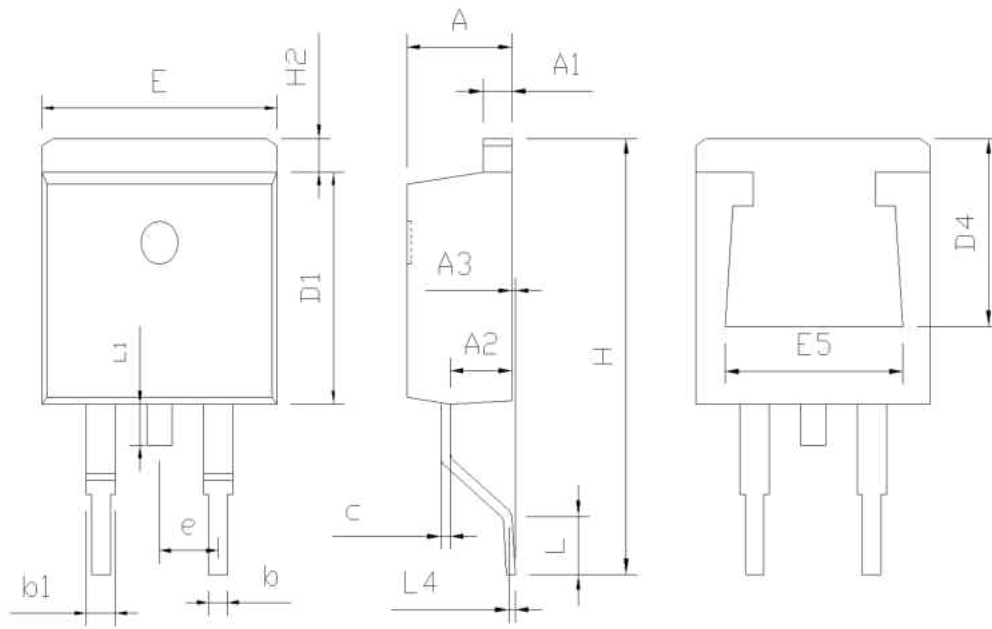

SYMBOL	mm		
	MIN	NOM	MAX
A	4.37	4.57	4.77
A1	1.22	1.27	1.42
A2	2.49	2.69	2.89
A3	0.00	0.13	0.25
b	0.70	0.81	0.96
b1	1.17	1.27	1.47
c	0.30	0.38	0.53
D1	8.50	8.70	8.90
D4	6.60	-	-
E	9.86	10.16	10.36
E5	7.06	-	-
e	2.54 BSC		
H	14.70	15.10	15.50
H2	1.07	1.27	1.47
L	2.00	2.30	2.60
L1	1.40	1.55	1.70
L4	0.25 BSC		



■ Package Information

Figure4, TO247 package outline dimension

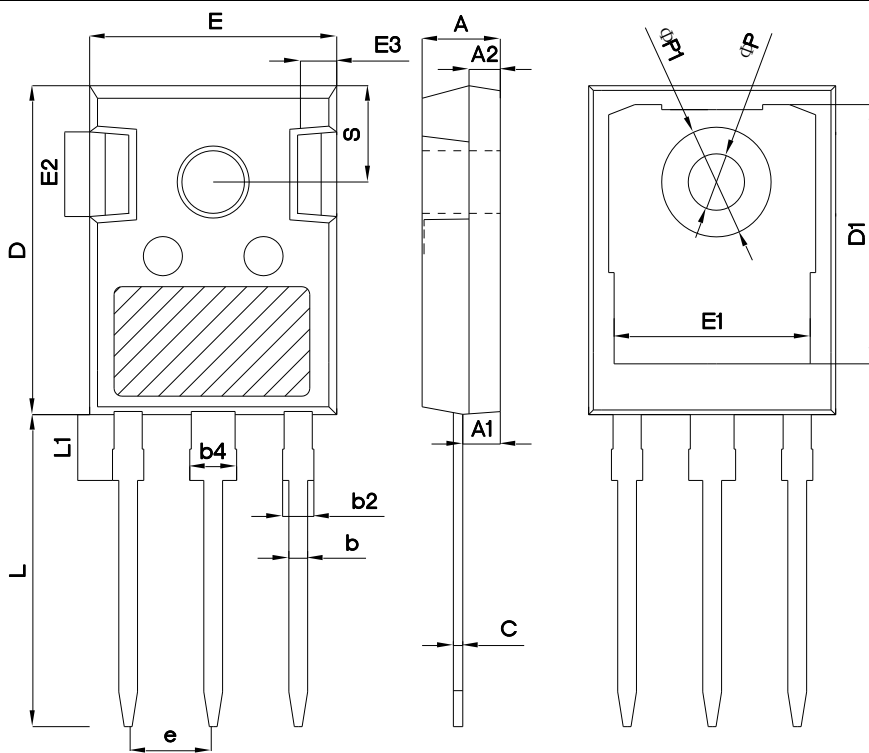

SYMBOL	mm		
	MIN	NOM	MAX
A	4.80	5.00	5.20
A1	2.21	2.41	2.59
A2	1.85	2.00	2.15
b	1.11	1.21	1.36
b2	1.91	2.01	2.21
b4	2.91	3.01	3.21
c	0.51	0.61	0.75
D	20.80	21.00	21.30
D1	16.25	16.55	16.85
E	15.50	15.80	16.10
E1	13.00	13.30	13.60
E2	4.80	5.00	5.20
E3	2.30	2.50	2.70
e	5.44BSC		
L	19.82	19.92	20.22
L1	-	-	4.30
ΦP	3.40	3.60	3.80
ΦP1	-	-	7.30
S	6.15BSC		



■ Ordering Information

Package	Units/Tube	Tubes/Inner Box	Units/Inner Box	Inner Box/Carton Box	Units/Carton Box
TO220F	50	20	1000	6	6000
TO220	50	20	1000	6	6000
TO263	50	20	1000	6	6000
TO247	30	11	330	6	1980

■ Product Information

Product	Package	Pb Free	RoHS	Halogen Free
OSG65R200FF	TO220F	yes	yes	yes
OSG65R200PF	TO220	yes	yes	yes
OSG65R200KF	TO263	yes	yes	yes
OSG65R200HF	TO247	yes	yes	yes