

# Enhancement Mode N-Channel Power MOSFET

## Features

- ◆ Low  $R_{DS(on)}$  & FOM
- ◆ Extremely low switching loss
- ◆ Excellent stability and uniformity
- ◆ Easy to drive
- ◆ EMI and performance balanced

## Applications



- ◆ Lighting
- ◆ Hard switching PWM
- ◆ Server power supply
- ◆ Charger

## ■ General Description

OSG65R200FEF uses advanced GreenMOST™ technology to provide low  $R_{DS(ON)}$ , low gate charge, fast switching and excellent avalanche characteristics. This device is suitable for active power factor correction and switching mode power supply applications.

◆ $V_{DS, min@Tjmax}$	700 V
◆ $I_{D, pulse}$	60 A
◆ $R_{DS(ON), max @ V_{GS}=10 V}$	200 mΩ
◆ $Q_g$	22.5 nC

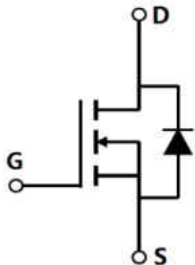
## ■ Schematic and Package Information

<b>Schematic Diagram</b> 	<b>Pin Assignment Top View</b>  <b>TO220F</b> <b>OSG65R200FEF</b>
--	---

## ■ Absolute Maximum Ratings at $T_j=25^{\circ}\text{C}$ unless otherwise noted

Parameter	Symbol	Value	Unit
Drain source voltage	$V_{DS}$	650	V
Gate source voltage	$V_{GS}$	±30	V
Continuous drain current <sup>1)</sup> , $T_C=25^{\circ}\text{C}$	$I_D$	20	A
Continuous drain current <sup>1)</sup> , $T_C=100^{\circ}\text{C}$		12.5	
Pulsed drain current <sup>2)</sup> , $T_C=25^{\circ}\text{C}$	$I_{D, pulse}$	60	A
Power dissipation <sup>3)</sup> , $T_C=25^{\circ}\text{C}$	$P_D$	34	W
Single pulsed avalanche energy <sup>5)</sup>	$E_{AS}$	600	mJ
MOSFET dv/dt ruggedness, $V_{DS}=0\dots480\text{ V}$	dv/dt	50	V/ns
Reverse diode dv/dt, $V_{DS}=0\dots480\text{ V}$ , $I_{SD}\leq I_D$	dv/dt	15	V/ns
Operation and storage temperature	$T_{stg}, T_j$	-55 to 150	°C

## ■ Thermal Characteristics

Parameter	Symbol	Value	Unit
Thermal resistance, junction-case	$R_{\theta JC}$	3.67	°C/W
Thermal resistance, junction-ambient <sup>4)</sup>	$R_{\theta JA}$	62.5	°C/W

## ■ Electrical Characteristics at $T_j=25\text{ °C}$ unless otherwise specified

Parameter	Symbol	Min.	Typ.	Max.	Unit	Test condition
Drain-source breakdown voltage	$BV_{DSS}$	650			V	$V_{GS}=0\text{ V}$ , $I_D=250\text{ }\mu\text{A}$
		700	770			$V_{GS}=0\text{ V}$ , $I_D=250\text{ }\mu\text{A}$ , $T_j=150\text{ °C}$
Gate threshold voltage	$V_{GS(th)}$	2.9		3.9	V	$V_{DS}=V_{GS}$ , $I_D=250\text{ }\mu\text{A}$
Drain-source on-state resistance	$R_{DS(on)}$		0.16	0.2	$\Omega$	$V_{GS}=10\text{ V}$ , $I_D=10\text{ A}$
			0.42			$V_{GS}=10\text{ V}$ , $I_D=10\text{ A}$ , $T_j=150\text{ °C}$
Gate-source leakage current	$I_{GSS}$			100	nA	$V_{GS}=30\text{ V}$
				-100		$V_{GS}=-30\text{ V}$
Drain-source leakage current	$I_{DSS}$			1	$\mu\text{A}$	$V_{DS}=650\text{ V}$ , $V_{GS}=0\text{ V}$

## ■ Dynamic Characteristics

Parameter	Symbol	Min.	Typ.	Max.	Unit	Test condition
Input capacitance	$C_{iss}$		1376.8		pF	$V_{GS}=0\text{ V}$ , $V_{DS}=50\text{ V}$ , $f=100\text{ kHz}$
Output capacitance	$C_{oss}$		103.0		pF	
Reverse transfer capacitance	$C_{rss}$		2.1		pF	
Turn-on delay time	$t_{d(on)}$		32.3		ns	$V_{GS}=10\text{ V}$ , $V_{DS}=400\text{ V}$ , $R_G=2\text{ }\Omega$ , $I_D=10\text{ A}$
Rise time	$t_r$		22.8		ns	
Turn-off delay time	$t_{d(off)}$		58.7		ns	
Fall time	$t_f$		4.8		ns	

## ■ Gate Charge Characteristics

Parameter	Symbol	Min.	Typ.	Max.	Unit	Test condition
Total gate charge	$Q_g$		22.5		nC	$I_D=10\text{ A}$ , $V_{DS}=400\text{ V}$ , $V_{GS}=10\text{ V}$
Gate-source charge	$Q_{gs}$		6.0		nC	
Gate-drain charge	$Q_{gd}$		7.3		nC	
Gate plateau voltage	$V_{\text{plateau}}$		5.6		V	

## ■ Body Diode Characteristics

Parameter	Symbol	Min.	Typ.	Max.	Unit	Test condition
Diode forward current	$I_S$			20	A	$V_{GS} < V_{th}$
Pulsed source current	$I_{SP}$			60		
Diode forward voltage	$V_{SD}$			1.3	V	$I_S=20\text{ A}$ , $V_{GS}=0\text{ V}$
Reverse recovery time	$t_{rr}$		300.8		ns	$V_R=400\text{ V}$ , $I_S=10\text{ A}$ , $di/dt=100\text{ A}/\mu\text{s}$
Reverse recovery charge	$Q_{rr}$		3.3		$\mu\text{C}$	
Peak reverse recovery current	$I_{rrm}$		25.3		A	

## ■ Note

- 1) Calculated continuous current based on maximum allowable junction temperature.
- 2) Repetitive rating; pulse width limited by max. junction temperature.
- 3)  $P_d$  is based on max. junction temperature, using junction-case thermal resistance.
- 4) The value of  $R_{\theta JA}$  is measured with the device mounted on 1 in 2 FR-4 board with 2oz. Copper, in a still air environment with  $T_a=25\text{ }^\circ\text{C}$ .
- 5)  $V_{DD}=100\text{ V}$ ,  $R_G=25\text{ }\Omega$ ,  $L=60\text{ mH}$ , starting  $T_j=25\text{ }^\circ\text{C}$ .

■ **Electrical Characteristics Diagrams**

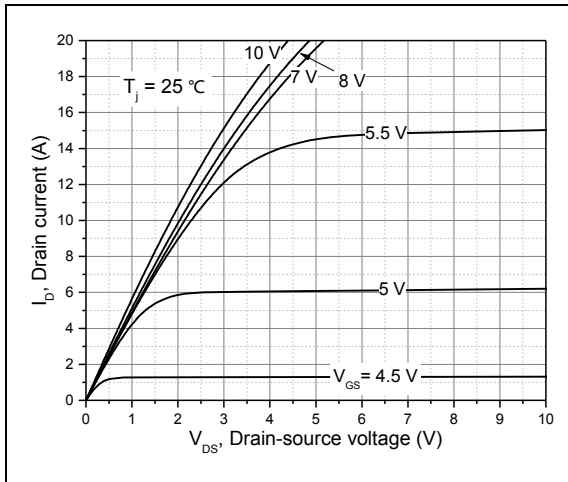

Figure 1, Typ. output characteristics

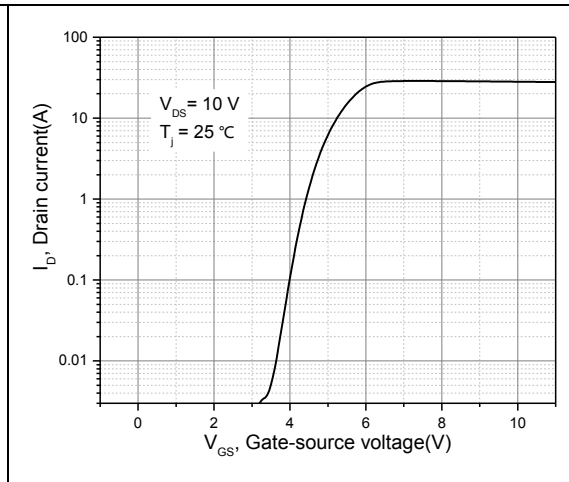

Figure 2, Typ. transfer characteristics

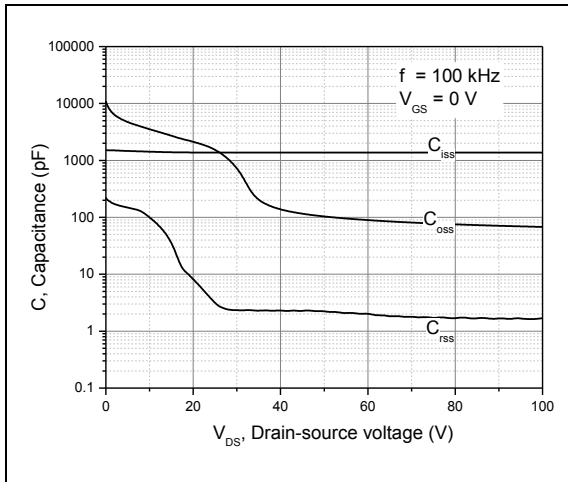

Figure 3, Typ. capacitances

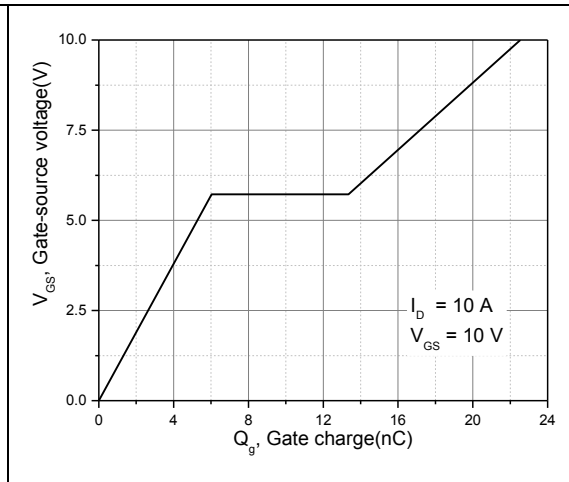

Figure 4, Typ. gate charge

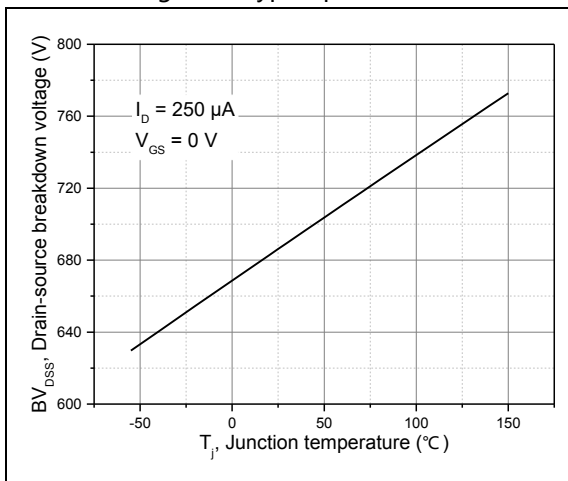

Figure 5, Drain-source breakdown voltage

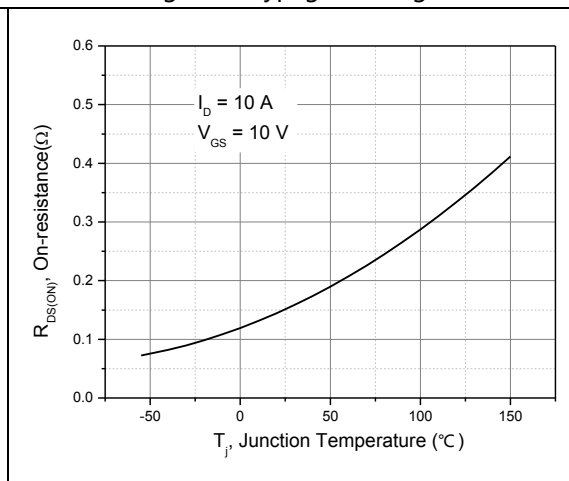

Figure 6, Drain-source on-state resistance

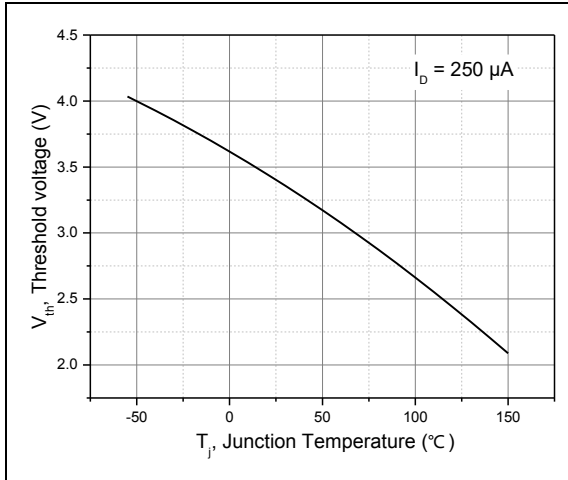

Figure 7, Threshold voltage

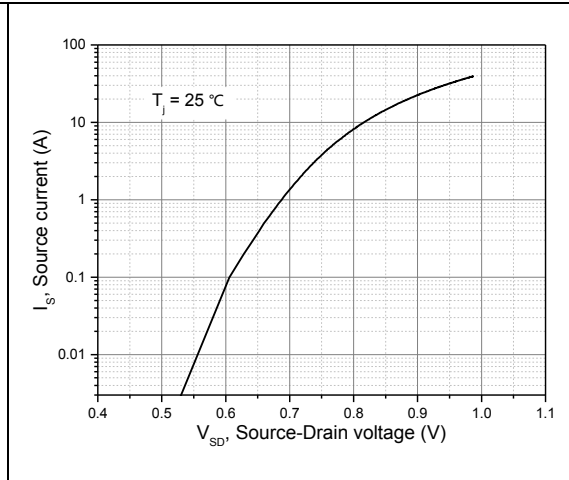

Figure 8, Forward characteristic of body diode

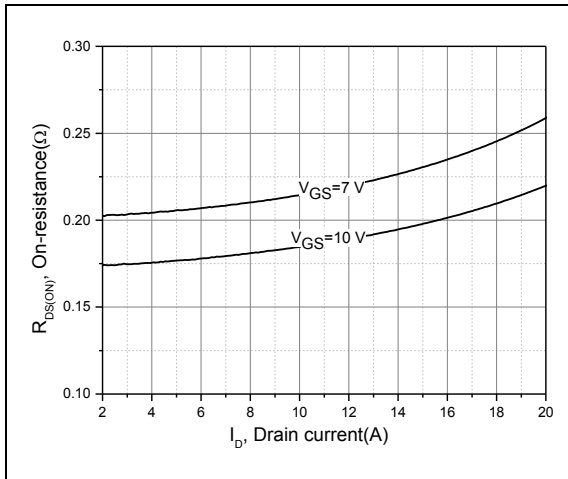

Figure 9, Drain-source on-state resistance

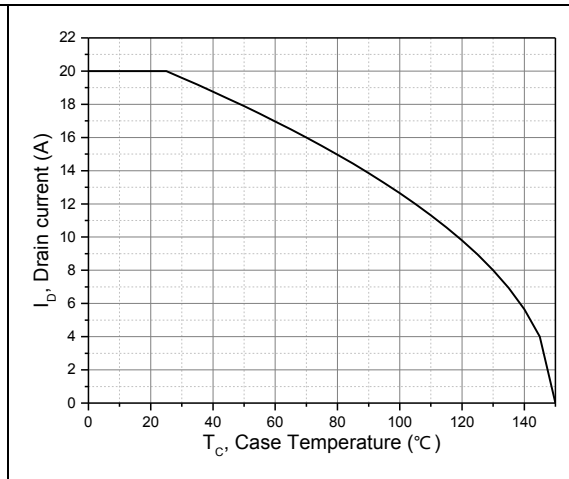

Figure 10, Drain current

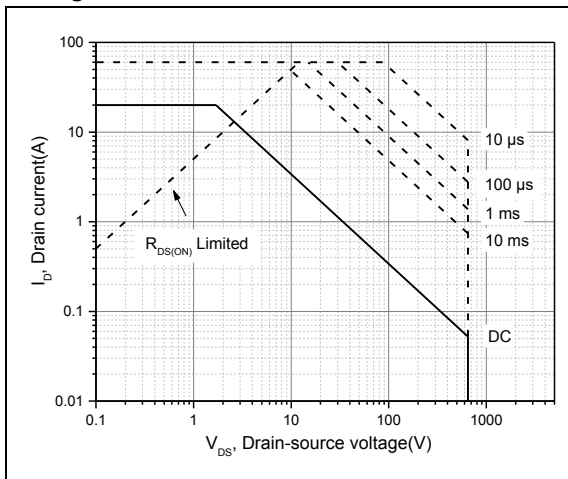

Figure 11, Safe operation area,  $T_C=25\text{ }^\circ\text{C}$

■ Test circuits and waveforms

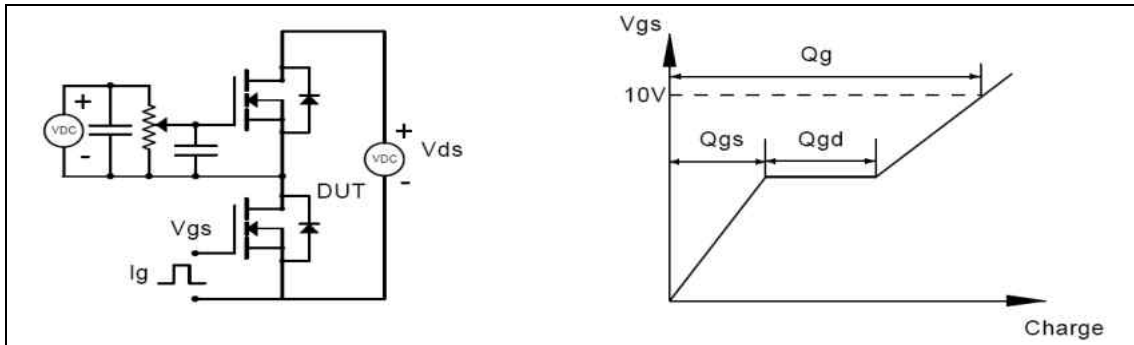

Figure 1, Gate charge test circuit & waveform

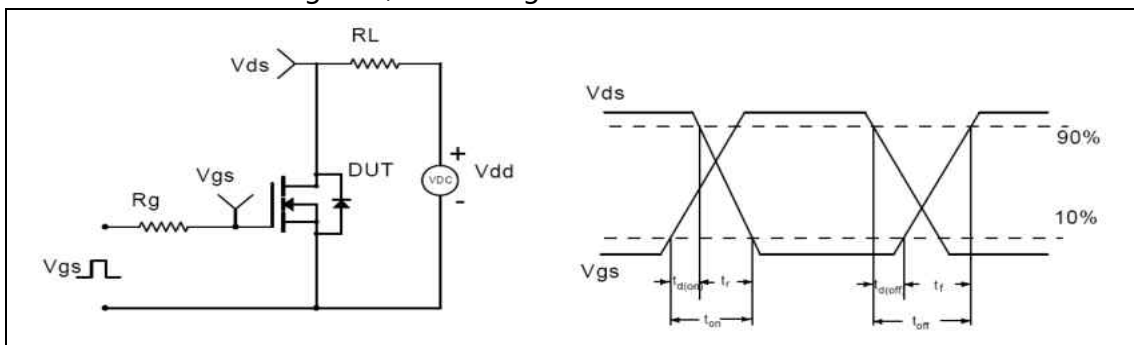

Figure 2, Switching time test circuit & waveforms

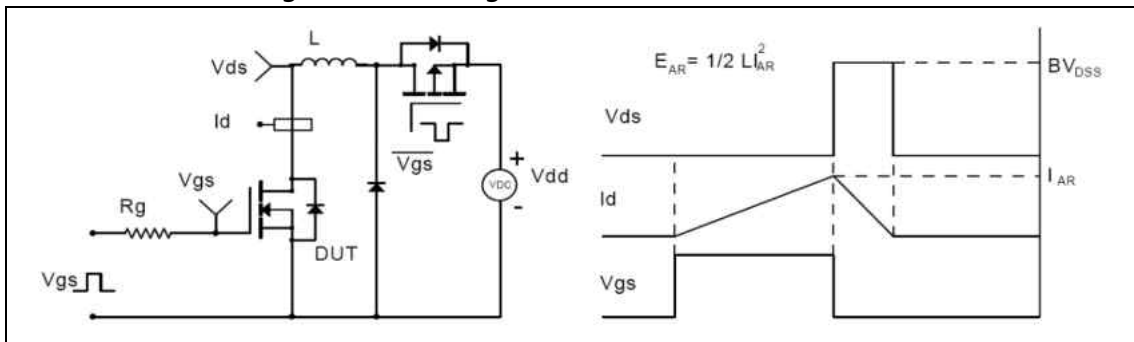

Figure 3, Unclamped inductive switching (UIS) test circuit & waveforms

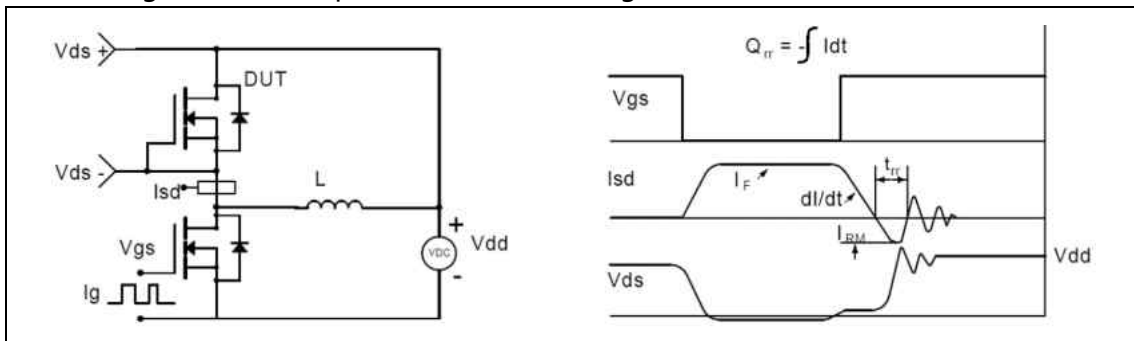
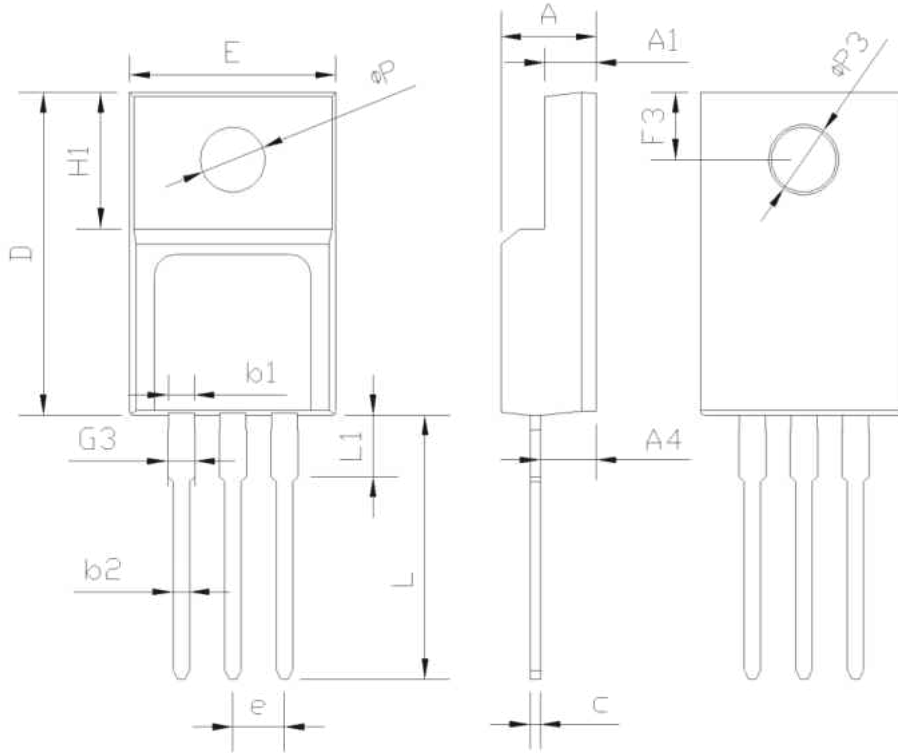

Figure 4, Diode reverse recovery test circuit & waveforms

**■ Package Information**

Figure1, TO220F package outline dimension



SYMBOL	mm		
	MIN	NOM	MAX
E	9.96	10.16	10.36
A	4.50	4.70	4.90
A1	2.34	2.54	2.74
A2	0.30	0.45	0.60
A4	2.56	2.76	2.96
c	0.40	0.50	0.65
c1	1.20	1.30	1.35
D	15.57	15.87	16.17
H1	6.70REF		
e	2.54BSC		
L	12.68	12.98	13.28
L1	2.88	3.03	3.18
ΦP	3.03	3.18	3.38
ΦP3	3.15	3.45	3.65
F3	3.15	3.30	3.45
G3	1.25	1.35	1.55
b1	1.18	1.28	1.43
b2	0.70	0.80	0.95



---

**■ Ordering Information**

---

Package	Units/Tube	Tubes/Inner Box	Units/Inner Box	Inner Box/Carton Box	Units/Carton Box
TO220F	50	20	1000	6	6000

---

**■ Product Information**

---

Product	Package	Pb Free	RoHS	Halogen Free
OSG65R200FEF	TO220F	yes	yes	yes