

OSG65R340FZF_Datasheet

Enhancement Mode N-Channel Power MOSFET

Features

- ◆ Ultra-fast and robust body diode
- ◆ Low $R_{DS(on)}$ & FOM
- ◆ Excellent low switching loss
- ◆ Excellent stability and uniformity
- ◆ Easy to drive

Applications



- ◆ Lighting
- ◆ Server power supply
- ◆ Telecom
- ◆ Solar invertor

■ General Description

OSG65R340FZF uses advanced GreenMOS™ technology to provide low $R_{DS(ON)}$, low gate charge, fast switching and excellent avalanche characteristics. This device offers extremely fast and robust body diode, and is suitable for telecom and power supplies.

◆ $V_{DS, min@Tjmax}$	700 V
◆ $I_{D, pulse}$	45 A
◆ $R_{DS(ON), max @ V_{GS}=10 V}$	340 mΩ
◆ Q_g	15.6 nC

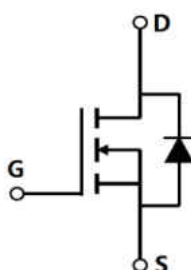
■ Schematic and Package Information

Schematic Diagram 	Pin Assignment-Top View  TO220F OSG65R340FZF
--	---

■ Absolute Maximum Ratings at $T_j=25^\circ\text{C}$ unless otherwise noted

Parameter	Symbol	Value	Unit
Drain source voltage	V_{DS}	650	V
Gate source voltage	V_{GS}	± 30	V
Continuous drain current ¹⁾ , $T_C=25^\circ\text{C}$	I_D	15	A
Continuous drain current ¹⁾ , $T_C=100^\circ\text{C}$		9.5	
Pulsed drain current ²⁾ , $T_C=25^\circ\text{C}$	$I_{D, pulse}$	45	A
Power dissipation ³⁾ , $T_C=25^\circ\text{C}$	P_D	32	W
Single pulsed avalanche energy ⁵⁾	E_{AS}	120	mJ
MOSFET dV/dt ruggedness, $V_{DS}=0\dots 480\text{ V}$	dV/dt	50	V/ns
Reverse diode dV/dt , $V_{DS}=0\dots 480\text{ V}$, $I_{SD}\leq I_D$	dV/dt	50	V/ns
Operation and storage temperature	T_{stg}, T_j	-55 to 150	$^\circ\text{C}$

■ Thermal Characteristics

Parameter	Symbol	Value	Unit
Thermal resistance, junction-case	$R_{\theta JC}$	3.9	$^{\circ}\text{C}/\text{W}$
Thermal resistance, junction-ambient ⁴⁾	$R_{\theta JA}$	62.5	$^{\circ}\text{C}/\text{W}$

■ Electrical Characteristics at $T_j=25^{\circ}\text{C}$ unless otherwise specified

Parameter	Symbol	Min.	Typ.	Max.	Unit	Test condition
Drain-source breakdown voltage	BV_{DSS}	650			V	$V_{GS}=0\text{ V}, I_D=250\ \mu\text{A}$
		700	795			$V_{GS}=0\text{ V}, I_D=250\ \mu\text{A}$ $T_j=150^{\circ}\text{C}$
Gate threshold voltage	$V_{GS(th)}$	3.3		4.3	V	$V_{DS}=V_{GS}, I_D=250\ \mu\text{A}$
Drain-source on-state resistance	$R_{DS(on)}$		0.26	0.34	Ω	$V_{GS}=10\text{ V}, I_D=7.5\text{ A}$
			0.69			$V_{GS}=10\text{ V}, I_D=7.5\text{ A},$ $T_j=150^{\circ}\text{C}$
Gate-source leakage current	I_{GSS}			100	nA	$V_{GS}=30\text{ V}$
				-100		$V_{GS}=-30\text{ V}$
Drain-source leakage current	I_{DSS}			10	μA	$V_{DS}=650\text{ V}, V_{GS}=0\text{ V}$

■ Dynamic Characteristics

Parameter	Symbol	Min.	Typ.	Max.	Unit	Test condition
Input capacitance	C_{iss}		1065.7		pF	$V_{GS}=0\text{ V},$ $V_{DS}=50\text{ V},$ $f=100\text{ kHz}$
Output capacitance	C_{oss}		73.0		pF	
Reverse transfer capacitance	C_{rss}		2.2		pF	
Turn-on delay time	$t_{d(on)}$		25.7		ns	$V_{GS}=10\text{ V},$ $V_{DS}=400\text{ V},$ $R_G=2\ \Omega,$ $I_D=8\text{ A}$
Rise time	t_r		6.5		ns	
Turn-off delay time	$t_{d(off)}$		32.6		ns	
Fall time	t_f		3.9		ns	

■ Gate Charge Characteristics

Parameter	Symbol	Min.	Typ.	Max.	Unit	Test condition
Total gate charge	Q_g		15.6		nC	$I_D=8\text{ A}$, $V_{DS}=400\text{ V}$, $V_{GS}=10\text{ V}$
Gate-source charge	Q_{gs}		5.6		nC	
Gate-drain charge	Q_{gd}		5.2		nC	
Gate plateau voltage	V_{plateau}		6.9		V	

■ Body Diode Characteristics

Parameter	Symbol	Min.	Typ.	Max.	Unit	Test condition
Diode forward current	I_S			15	A	$V_{GS}<V_{th}$
Pulsed source current	I_{SP}			45		
Diode forward voltage	V_{SD}			1.3	V	$I_S=15\text{ A}$, $V_{GS}=0\text{ V}$
Reverse recovery time	t_{rr}		102.9		ns	$V_R=400\text{ V}$, $I_S=8\text{ A}$, $di/dt=100\text{ A}/\mu\text{s}$
Reverse recovery charge	Q_{rr}		0.5		μC	
Peak reverse recovery current	I_{rrm}		9.5		A	

■ Note

- 1) Calculated continuous current based on maximum allowable junction temperature.
- 2) Repetitive rating; pulse width limited by max. junction temperature.
- 3) P_d is based on max. junction temperature, using junction-case thermal resistance.
- 4) The value of $R_{\theta JA}$ is measured with the device mounted on 1 in 2 FR-4 board with 2oz. Copper, in a still air environment with $T_a=25\text{ }^\circ\text{C}$.
- 5) $V_{DD}=100\text{ V}$, $R_G=25\text{ }\Omega$, $L=10\text{ mH}$, starting $T_j=25\text{ }^\circ\text{C}$.

■ **Electrical Characteristics Diagrams**

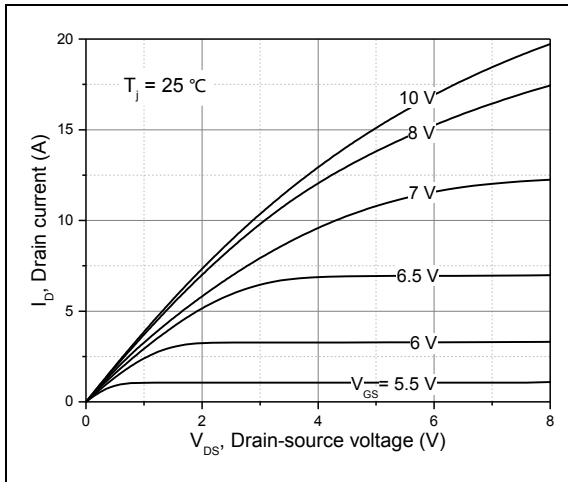

Figure 1, Typ. output characteristics

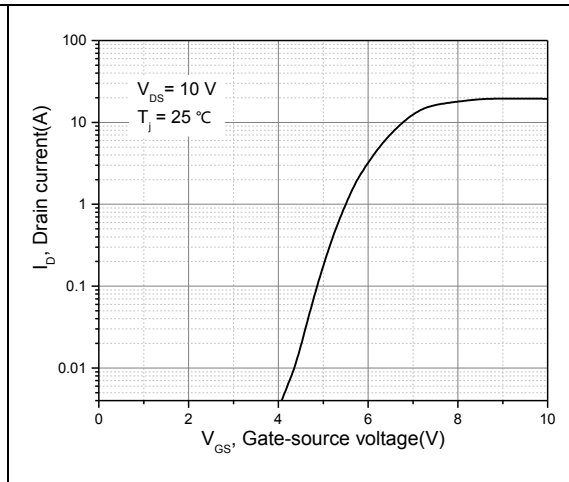

Figure 2, Typ. transfer characteristics

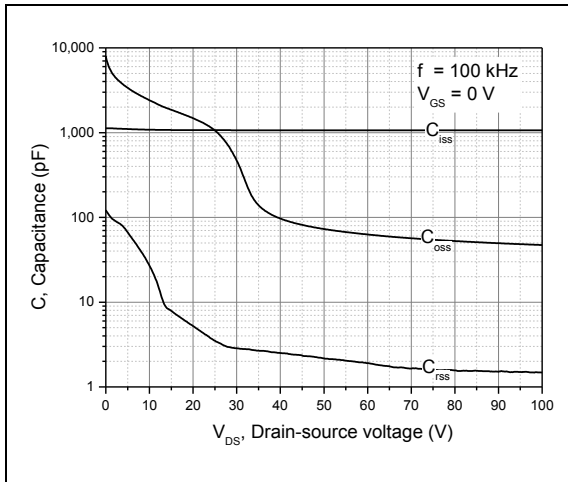

Figure 3, Typ. capacitances

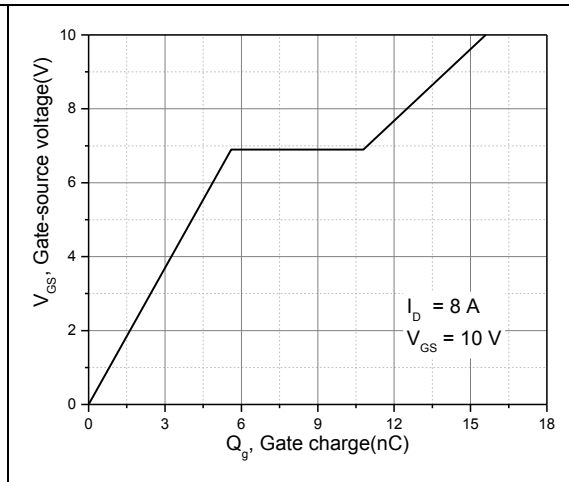

Figure 4, Typ. gate charge

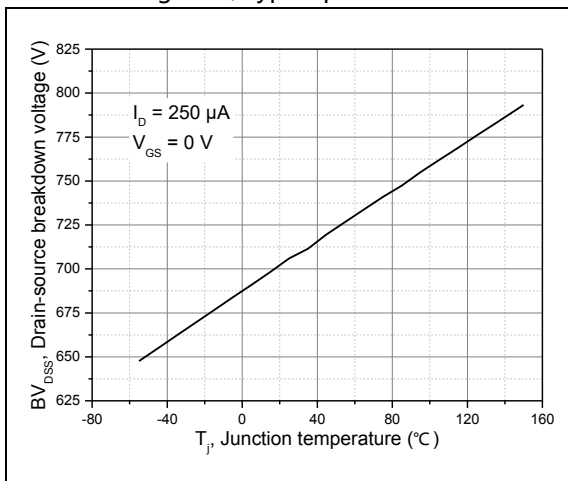

Figure 5, Drain-source breakdown voltage

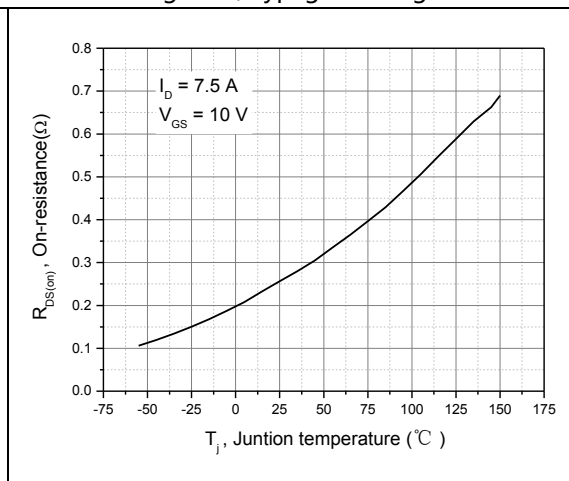

Figure 6, Drain-source on-state resistance

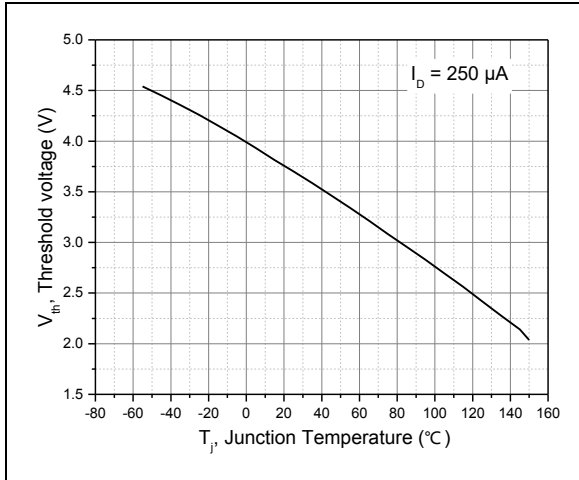

Figure 7, Threshold voltage

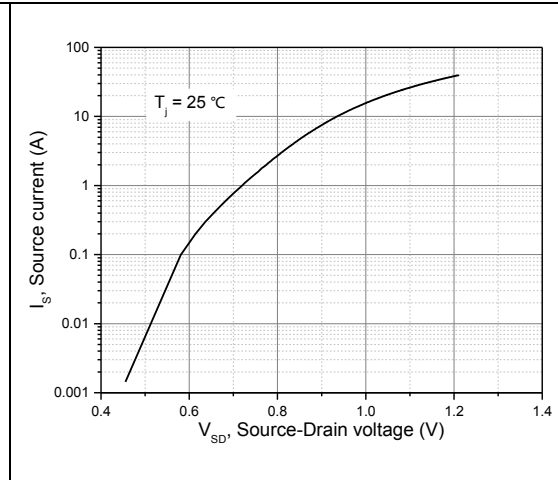

Figure 8, Forward characteristic of body diode

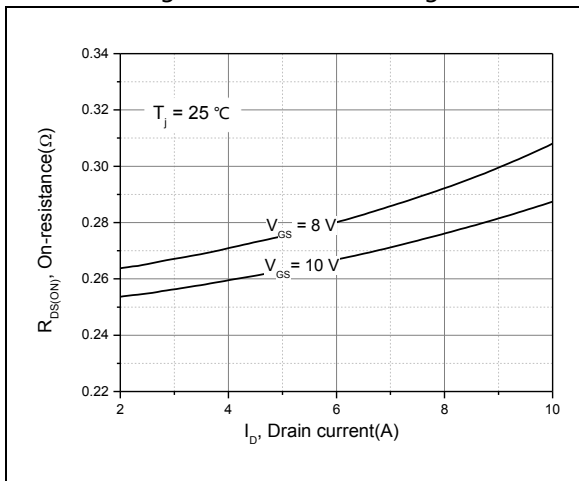

Figure 9, Drain-source on-state resistance

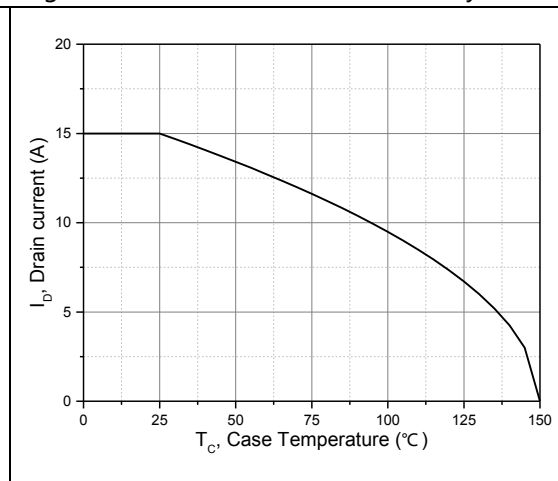

Figure 10, Drain current

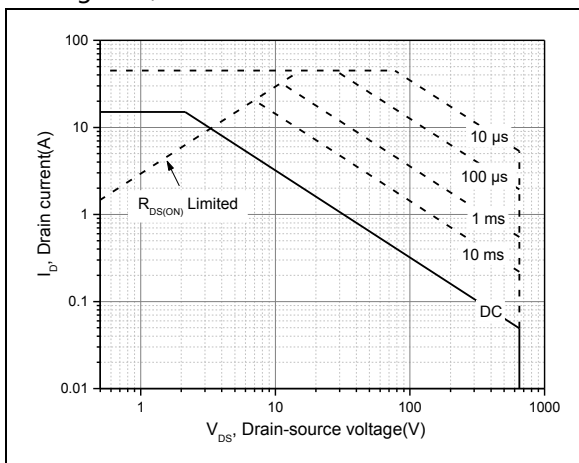

Figure 11, Safe operation area $T_C = 25 \text{ }^\circ\text{C}$

■ Test circuits and waveforms

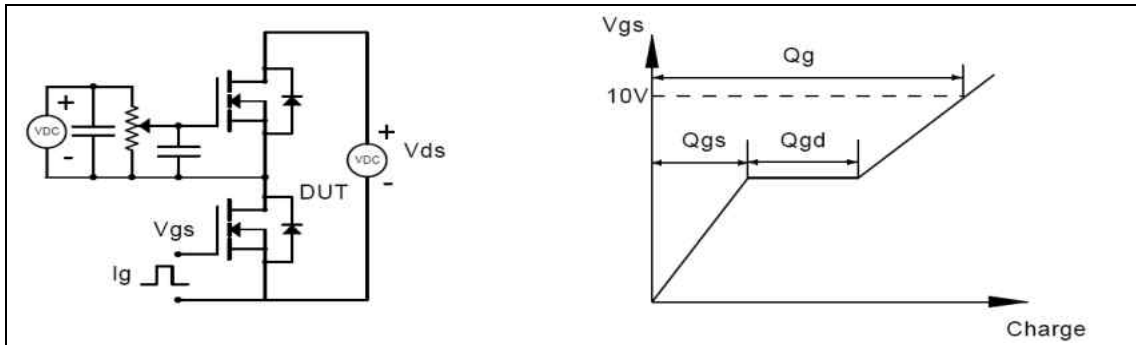

Figure 1, Gate charge test circuit & waveform

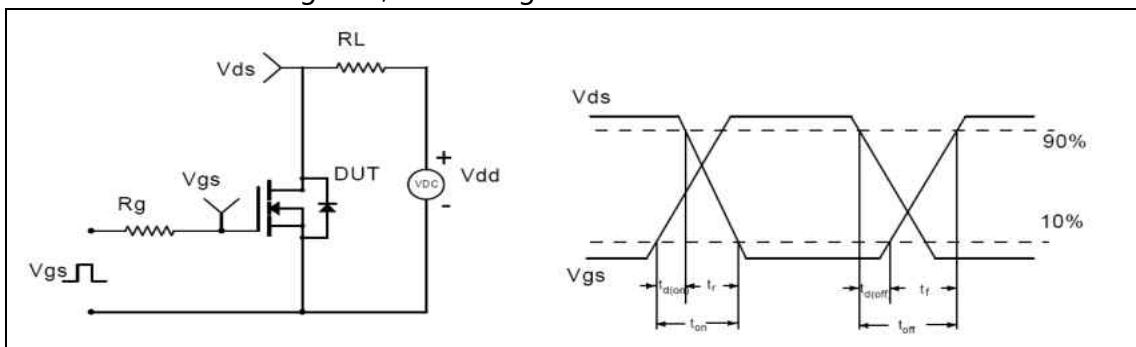

Figure 2, Switching time test circuit & waveforms

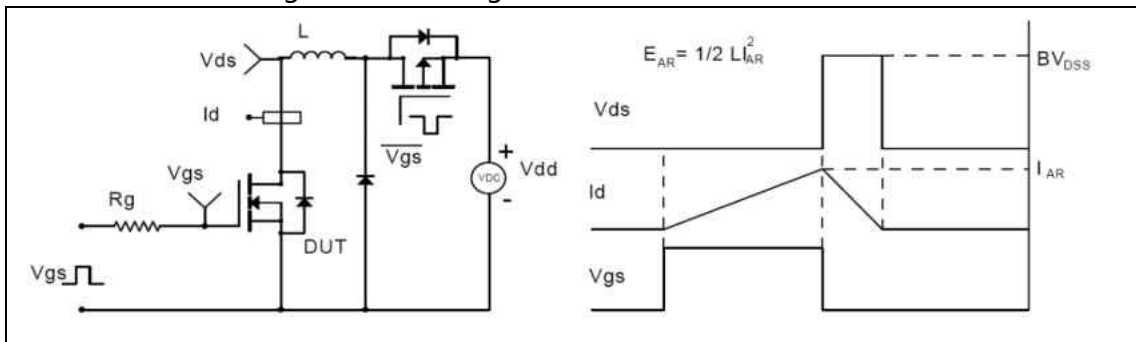

Figure 3, Unclamped inductive switching (UIS) test circuit & waveforms

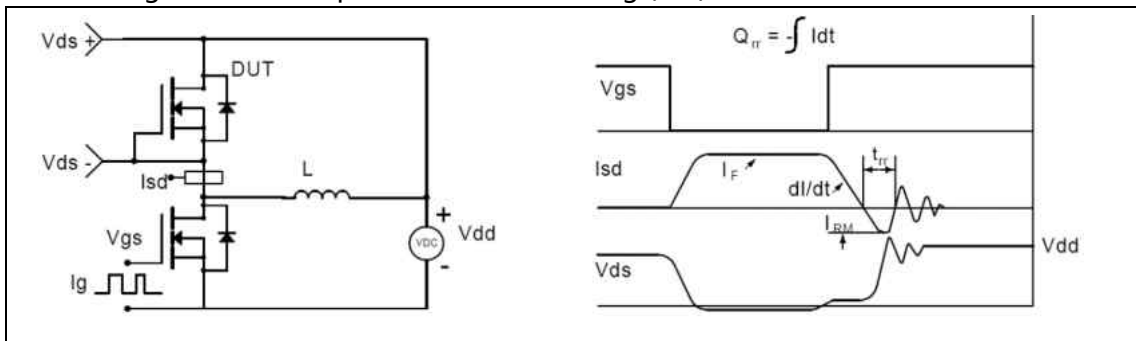
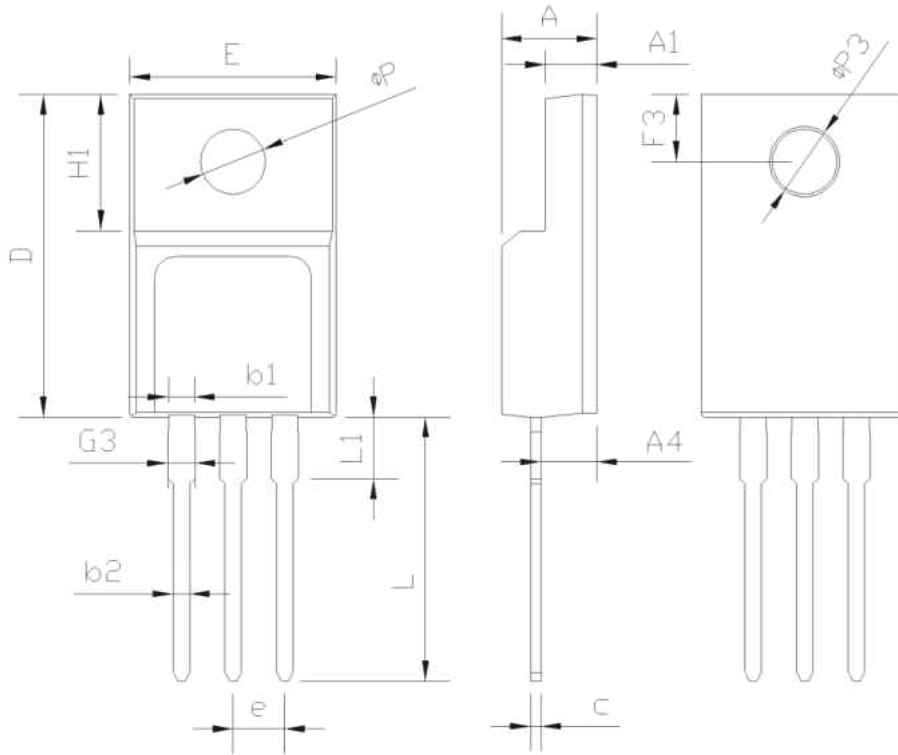

Figure 4, Diode reverse recovery test circuit & waveforms

■ Package Information

Figure1, TO220F package outline dimension



SYMBOL	mm		
	MIN	NOM	MAX
E	9.96	10.16	10.36
A	4.50	4.70	4.90
A1	2.34	2.54	2.74
A4	2.56	2.76	2.96
c	0.40	0.50	0.65
D	15.57	15.87	16.17
H1	6.70REF		
e	2.54BSC		
L	12.68	12.98	13.28
L1	2.88	3.03	3.18
ΦP	3.03	3.18	3.38
ΦP3	3.15	3.45	3.65
F3	3.15	3.30	3.45
G3	1.25	1.35	1.55
b1	1.18	1.28	1.43
b2	0.70	0.80	0.95

■ Ordering Information

Package	Units/Tube	Tubes/Inner Box	Units/Inner Box	Inner Box/Carton Box	Units/Carton Box
TO220F	50	20	1000	6	6000

■ Product Information

Product	Package	Pb Free	RoHS	Halogen Free
OSG65R340FZF	TO220F	yes	yes	yes